



भारतीय रिज़र्व बैंक
संपदा विभाग
तिरुवनंतपुरम
निविदा आमंत्रण सूचना

बैंक के स्टाफ क्वार्टर, तम्मलम, तिरुवनंतपुरम में अधिकारी फ्लैट (ई-08) के नवीनीकरण के लिए निविदा

भारतीय रिज़र्व बैंक, तिरुवनंतपुरम 10 से 25 लाख के बीच लागत वाले कार्य की उक्त श्रेणी के अंतर्गत बैंक के सूचीबद्ध विक्रेताओं/ठेकेदारों से उपर्युक्त कार्य के लिए ई-निविदाएँ आमंत्रित करता है। निविदाएँ एमएसटीसी लिमिटेड के ई-टेंडरिंग पोर्टल (<https://www.mstcecommerce.com/eprocn/>) के माध्यम से की जाएँगी। सभी इच्छुक सूचीबद्ध विक्रेताओं/ठेकेदारों को निविदा प्रक्रिया में भाग लेने के लिए उपर्युक्त वेबसाइट के माध्यम से एमएसटीसी लिमिटेड के साथ स्वयं को पंजीकृत करना होगा। ई-निविदा की अनुसूची इस प्रकार है:

a. कार्य का नाम	बैंक के स्टाफ क्वार्टर, तम्मलम, तिरुवनंतपुरम में अधिकारी फ्लैट (ई-08) का नवीनीकरण।
b. कार्य की अनुमानित लागत	₹15.00 लाख जीएसटी सहित
c. ई-निविदा संख्या	RBI/Thiruvananthapuram/Estate/9/24-25/ET/491
d. निविदा का तरीका	ई-प्रोक्योरमेंट प्रणाली (ऑनलाइन: भाग I - तकनीकी-वाणिज्यिक बोली और भाग II - मूल्य बोली (https://www.mstcecommerce.com/eprocn/) के माध्यम से)
e. बयाना राशि	कार्य सौंपे जाने पर सफल बोलीदाता से कार्य के मूल्य का 2% एनईएफटी के माध्यम से लिया जाएगा। लाभार्थी का नाम: एस्टेट लाभार्थी खाता संख्या: 8614038 IFSC: RBIS0THPA01
f. एनआईटी/निविदा की तिथि पार्टियों के लिए आरबीआई वेबसाइट/एमएसटीसी पोर्टल पर देखने के लिए उपलब्ध है	07 अक्टूबर, 2024 अपराह्न 03:00 बजे से
g. एमएसटीसी पोर्टल में तकनीकी-वाणिज्यिक बोली और मूल्य बोली प्रस्तुत करने के लिए ई-निविदा शुरू होने की तिथि	28 अक्टूबर, 2024 अपराह्न 03:00 बजे से

h. तकनीकी-वाणिज्यिक बोली और मूल्य बोली प्रस्तुत करने के लिए ऑनलाइन ई-निविदा बंद होने की तिथि	07 नवंबर, 2024 अपराह्न 03:00 बजे तक
j. निविदा खुलने की तिथि एवं समय	07 नवंबर, 2024 अपराह्न 04:00 बजे
k. लेनदेन शुल्क	एमएसटीसी लिमिटेड द्वारा प्रभारित

2. विक्रेता कृपया ध्यान दे कि नए एमएसटीसी पोर्टल का मार्ग इस प्रकार है:
<https://www.mstcecommerce.com/> → eProcurement → Common Portal → Vendor Login.

3. यह नोटिस केवल सूचना के लिए प्रकाशित किया जा रहा है और यह इस सीमित निविदा को उद्धृत करने के लिए खुला आमंत्रण नहीं है। इस निविदा में भागीदारी केवल आमंत्रण द्वारा है और चयनित खरीद इकाई के सूचीबद्ध ठेकेदारों तक ही सीमित है। अनचाहे प्रस्तावों को अनदेखा किया जा सकता है। हालांकि, जो ठेकेदार भविष्य में ऐसी निविदाओं में भाग लेना चाहते हैं, वे प्रक्रिया के अनुसार आरबीआई के पास नामांकन के लिए आवेदन कर सकते हैं।

4. भविष्य में निविदा में यदि कोई संशोधन/शुद्धिपत्र जारी किया जाएगा तो उसे केवल आरबीआई वेबसाइट और एमएसटीसी वेबसाइट पर ही अधिसूचित किया जाएगा तथा समाचार पत्र में प्रकाशित नहीं किया जाएगा।

भारतीय रिज़र्व बैंक/ RESERVE BANK OF INDIA
संपदा विभाग/ ESTATE DEPARTMENT
तिरुवनंतपुरम/ THIRUVANANTHAPURAM - 695033

**तमालम स्थित बैंक के स्टाफ क्वार्टर्स में अधिकारी फ्लैट (E-08) के नवीकरण
केलिए निविदा**

**TENDER FOR RENOVATION OF OFFICER FLAT (E-08) AT BANK'S STAFF
QUARTERS, THAMALAM**

PART - I (TECHNO - COMMERCIAL BID)

	Activity	Date
1	Date of availability of Tender in RBI Website and MSTC Portal	October 07, 2024 from 03:00 PM
2	Date of start of submission of bids	October 28, 2024 from 03:00 PM
3	Last date of submission of Tender	November 07, 2024 by 03:00 PM
4	Date of opening of Tender	November 07, 2024 at 04:00 PM
5	Validity of the Tender for acceptance by the Bank	90 days from the date of opening of the Tender.

This document is the property of Reserve Bank of India (RBI). It may not be copied, distributed or recorded on any medium, electronic or otherwise, without the RBI's written permission thereof, except for the purpose of responding to RBI for the said purpose. The use of the contents of this document, even by the authorized personnel / agencies for any purpose other than the purpose specified herein, is strictly prohibited and shall amount to copyright violation and thus, shall be punishable under the Indian Law

DISCLAIMER

Reserve Bank of India, Estate Department, Thiruvananthapuram, has prepared this document to give background information on the Project to the interested parties. While Reserve Bank of India has taken due care in the preparation of the information contained herein and believe it to be in order, neither Reserve Bank of India nor any of its authorities or agencies nor any of their respective officers, employees, agents or advisors give any warranty or make any representations, express or implied as to the completeness or accuracy of the information contained in this document or any information which may be provided in association with it.

The information is not intended to be exhaustive. Interested parties are required to make their own inquiries and respondents will be required to confirm in writing that they have done so and they do not rely only on the information provided by RBI in submitting the Tender. The information is provided on the basis that it is non – binding on Reserve Bank of India or any of its authorities or agencies or any of their respective officers, employees, agents or advisors.

Reserve Bank of India reserves the right not to proceed with the Project or to change the configuration of the Project, to alter the timetable reflected in this document or to change the process or procedure to be applied. It also reserves the right to decline to discuss the matter further with any party expressing interest. No reimbursement of cost of any type will be paid to persons or entities expressing interest.

NOTICE INVITING TENDER

Tender for renovation of Officer flat (E-08) at Bank's Staff quarters, Thamalam, Thiruvananthapuram.

Reserve Bank of India, Thiruvananthapuram invites e- tenders for the captioned work from Bank's empaneled vendors/contractors under the said category of the work costing between 10 to 25 Lakh. The tendering would be done through the e-Tendering portal of MSTC Ltd (<https://www.mstcecommerce.com/eprocn/>). All interested empaneled vendors /contractors must register themselves with MSTC Ltd through the above-mentioned website to participate in the tendering process. The Schedule of e-Tender is as follows:

a. Name of Work	Renovation of Officer flat (E-08) at Bank's Staff quarters, Thamalam, Thiruvananthapuram.
b. Estimated Cost of the Work	₹15.00 lakh inclusive of GST
c. e-Tender no	RBI/Thiruvananthapuram/Estate/9/24-25/ET/491
d. Mode of Tender	e-Procurement System (Online: Part I - Techno-Commercial Bid and Part II - Price Bid through https://www.mstcecommerce.com/eprocn/)
e. Earnest Money Deposit	Shall be collected from successful bidder @2% of the value of work, on awarding the work <u>in the form of NEFT</u> towards Beneficiary Name: ESTATE Beneficiary Ac No: 8614038 IFSC: RBIS0THPA01
f. Date of NIT/Tender available to parties to view in RBI website/MSTC Portal	October 07, 2024 from 03:00 PM
g. Date of start of e-Tender for submission of Techno-Commercial Bid and price Bid in MSTC Portal	October 28, 2024 from 03:00 PM
h. Date of close of online e-tender for submission of Techno-Commercial Bid & Price Bid	November 07, 2024 by 03:00 PM
j. Date & time of opening of tender	November 07, 2024 at 04:00 PM
k. Transaction Fee	As charged by MSTC Ltd.

Amendments / Corrigendum to the tender, if any, issued in future will only be notified on the RBI Website and MSTC Website as given above and will not be published in the newspaper.

Important instructions for E-Procurement

Bidders are requested to read the terms & conditions of this tender before submitting your online tender.

Process of e-Tender:

A) Registration: The process involves vendor's registration with MSTC e-procurement portal which is free of cost. Only after registration, the vendor(s) can submit his / their bids electronically. Electronic Bidding for submission of Techno-Commercial Bid as well as Price Bid will be done over the internet. The vendor should possess Class III signing type Digital Certificate. Vendors must make their own arrangement for bidding from a PC connected with internet. MSTC is not responsible for making such arrangement. (Bids will not be recorded without Digital Signature).

Special Note: The Techno-Commercial Bid and Price Bid must be submitted on-line through www.mstcecommerce.com/eprochome/rbi

- 1) Vendors are required to register themselves online with www.mstcecommerce.com => e-Procurement => PSU/Govt depts. => Select RBI Logo => Register as Vendor => Filling up details and creating own user id and password => Submit.
- 2) Vendors will receive a system generated mail confirming their registration in their e-mail which has been provided during filling the registration form. In case of any clarification, vendors may contact RBI / MSTC before the scheduled time of the e- tender.

Contact Persons (RBI - During Office Hours only):

1. Shri Shaji Krishnan (Assistant General Manager, Estate Department)
0471-278 3030/ (kshajikrishnan@rbi.org.in)

2. Shri M. Muthuraja (Assistant Manager, Estate Department)
0471-278 3029/ (muthurajam@rbi.org.in)

Contact Persons (MSTC Ltd – During Office Hours only):

Name	E-Mail ID	Landline No.	Mobile No.
Shri Ganesa Murthy	bmtvc@mstcindia.in	0471-2326686	09176616410
Shri Santosh Rajendran	skrajendran@mstcindia.co.in ; tvcopn3mstcindia.in	0471-2326686	08884600700

Kerala Branch Office details:

Address: 1st Floor, BSNL CTO Building, Opp Kerala State Secretariat, Mahathma Gandhi Rd, Statue, Thiruvananthapuram-695001	Mail ID: mstctvc@mstcindia.in	Contact: 0471-2326686
--	--	-----------------------

HO Central Help Desk: (For vendors)

Phone Number :07969066600

Email: helpdeskho@mstcindia.in (Please mention "HO Helpdesk" as subject while sending emails)

Availability: 9:30 AM to 5:00 PM on all working days for all Technical issues e-Tenders, System settings etc.

B) System Requirements:

- i) Windows 7 or above Operating System.
- ii) IE-7 and above Internet browser.
- iii) Signing type Digital Signature
- iv) Latest updated JRE 8 (x86 offline) software to be downloaded and installed in the system.

To disable “Protected Mode” for DSC to appear in the signer box following settings may be applied.

- Tools => Internet Options => Security => Disable protected Mode If enabled- i.e, Remove the tick from the tick box mentioning “Enable Protected Mode”.

Other Settings:

- Tools => Internet Options => General => Click on Settings under “browsing history / Delete Browsing History” => Temporary Internet Files => Activate “Every time I Visit the Webpage”.

To enable ALL active X controls and disable ‘use pop up blocker’ under Tools => Internet Options => custom level (Please run IE settings from the page www.mstcecommerce.com once)

The ‘Techno-Commercial Bid’ and the ‘Price Bid’ shall have to be submitted online at www.mstcecommerce.com/eprochome/rbi. Tenders will be opened electronically on specified date and time as given in the tender.

All entries in the tender should be entered in online Technical & Commercial Formats without any ambiguity.

Special Note towards Transaction fee:

The vendors shall pay the transaction fee using “**Transaction Fee Payment**” link under “My Menu” in the vendor login. The vendors have to select the particular tender from the event dropdown box. The vendor shall have the facility of making the payment either through NEFT or online payment. On selecting NEFT, the vendor shall generate a challan by filling up a form. The vendor shall remit the transaction fee amount as per the details printed on the challan without making change in the same. On selecting online payment, the vendor shall have the provision of making payment using its Credit / Debit Card / Net Banking. Once the payment gets credited to MSTC’s designated bank account, the transaction fee shall be auto authorized and the vendor shall be receiving a system generated mail. **Transaction fee is non-refundable.** A vendor will not have the access to online e-tender without making the payment towards transaction fee.

Note

Bidders are advised to remit the transaction fee well in advance before the closing time of the event so as to give themselves sufficient time to submit the bid.

Information about tenders / corrigendum uploaded shall be sent by email only during the process till finalization of tender. Hence the vendors are required to ensure that their e-mail ID provided is valid and updated at the time of registration of vendor with MSTC. Vendors are also requested to ensure validity of their DSC (Digital Signature Certificate).

E-tender cannot be accessed after the due date and time mentioned in NIT.

Bidding in e-Tender:

- a) The process involves Electronic Bidding for submission of 'Techno-Commercial Bid' and 'Price Bid'.
- b) The vendor(s) who have submitted transaction fee can only submit their Bids through internet in MSTC website www.mstcecommerce.com => e-procurement => PSU / Govt. depts => Login under RBI => My menu => Auction Floor Manager => live event => Selection of the live event.
- c) The vendor should have running JAVA application. This exercise has to be done immediately after opening of Bid floor. Then they have to fill up Common terms / Commercial specifications and save the same. After that, they should click on the 'Techno-Commercial Bid'. If this JAVA application does not run, then the vendor will not be able to save / submit his 'Techno-Commercial Bid'.
- e) After filling the 'Techno Commercial Bid', vendors must click 'save' for recording the same. Once the 'Price Bid' link becomes active and the details are filled up, vendors have to click on "save" to record the 'Price Bid'. After both the 'Techno-Commercial Bid' & 'Price Bid' have been saved, vendor must click on the "Final submission" button to register the bids.
- f) Pages of Part I (Techno-Commercial Bid) of the tender where details shall be filled in and signed, shall be downloaded from the uploaded tender documents, details filled in, signed and uploaded. Vendors are instructed to use 'Attach Doc' button to upload documents. Multiple documents can be uploaded.
- g) In all cases, vendors are advised to use their own ID and Password along with Digital Signature at the time of submission of their bids.
- h) During the entire e-tender process, the vendors will remain completely anonymous to one another and also to everybody else.
- i) The e-tender floor shall remain open from the pre-announced date & time and for as much duration as mentioned above.
- j) All electronic bids submitted during the e-tender process shall be legally binding on the vendor. Any bid will be considered as the valid bid offered by that vendor and acceptance of the same by the 'Buyer' will form a binding contract between 'Buyer' and the 'Vendor' for execution of the work.
- k) It is mandatory that all the bids are submitted with Digital Signature Certificate otherwise the same will not be accepted by the system.
- l) 'Buyer' reserves the right to cancel or reject or accept or withdraw or extend the tender in full or part, without assigning any reason thereof.

No deviation of the terms and conditions of the tender document is acceptable after opening of Part I of the tender. Submission of bid in the e-tender floor by any vendor confirms his acceptance of terms & conditions for the tender. Any order resulting from this tender shall be governed by the terms and conditions mentioned therein. The tender inviting authority has the right to cancel this e-tender or extend the due date of receipt of bid(s) without assigning any reasons thereof.

Vendors are requested to read the vendor guide and see the video in the page www.mstcecommerce.com/eprochome to familiarize them with the system before bidding.

Vendors are requested to quote rates without GST on 'Works Contract' and the total cost including GST shall be calculated by the system. No Change in quoted rates will be accepted.

Important Note

In the price bid due to number of words limitation, complete description could not be accommodated, and description given thereof is brief. Before quoting rates, all the contractors must read the complete details of each item given in the schedule of quantities and other specifications/terms and conditions given in this tender document. For execution and rate purpose, the details given in schedule of quantities in this tender document will be implemented.



**ESTATE DEPARTMENT
THIRUVANANTHAPURAM**

Renovation of Officer flat (E-08) at Bank's Staff quarters, Thamalam, Thiruvananthapuram.

Contents

SI No	Description	Page No
1)	Form of Tender	9 -10
2)	Instructions to Bidders	11
3)	General Conditions of Contract	16
4)	Special Conditions of the contract	31
5)	Safety Code	33
6)	Fire Safety Code	34
7)	Appendix Herein Before Referred	35
8)	List of Materials of approved brand and/or manufacturer	36
9)	Schedule of Quantities	37
10)	Articles Of Agreement	50
11)	Undertaking regarding debarment	56
12)	Drawings	57

खंड-ए /SECTION – A
प्रस्ताव का पत्र / LETTER OF OFFER

स्थान/ Place:

तारीख/ Date:

सेवा में/ To

श्री तोमस मातु/ Shri Thomas Mathew
क्षेत्रीय निर्देशक/ Regional Director
भारतीय रिज़र्व बैंक/ Reserve Bank of India,
तिरुवनंतपुरम/ Thiruvananthapuram – 695033

महोदय/ Sir,

यहाँ इसके बाद निर्दिष्ट ज्ञापन में विनिर्दिष्ट कार्यों के संबंध में विशेष विवरण, अभिकल्पना और मात्रा - अनुसूची की जाँच करने के पश्चात् और उक्त ज्ञापन में विनिर्दिष्ट कार्यों के स्थान को देखने और उसकी जाँच करने के बाद तथा निविदा को प्रभावित करने वाली अपेक्षित जानकारी प्राप्त करने के बाद, हम इसके द्वारा ऐसी सभी शर्तों के अनुरूप जो जिस रूप में लागू होगी, उक्त ज्ञापन में विनिर्दिष्ट कार्यों को समय-ज्ञापन में विनिर्दिष्ट समय के भीतर, संलग्न मात्रा - अनुसूची में उल्लिखित दरों पर तथा हर प्रकार से विनिर्देशों, अभिकल्पनाओं, रेखाचित्रों और निविदा की शर्तों में दिये गये लिखित अनुदेशों, "करार की शर्तों", विशेष शर्तों, मात्रा - अनुसूची और संविदा की शर्तों और उसके लिए उपलब्ध कराई जाने वाली सामग्री के साथ सप्लाई और कार्य का निष्पादन करने का प्रस्ताव करते हैं।

Having examined the specifications, drawings and Schedule of Quantities relating to the works specified in the memorandum hereinafter set out and having visited and examined the site of the works specified in the said Memorandum and having acquired the requisite information relating thereto as affecting the tender, I/we hereby offer to execute the works specified in the said Memorandum within the time specified in the said Memorandum at the rates mentioned in the Schedule of Quantities and in accordance in all respects with the Specifications, Designs and instructions in writing referred to in Conditions of Tender, the Articles of Agreement, Special Conditions, Schedule of Quantities and Conditions of Contract and with such materials as are provided for, by and in all other respects in accordance with such conditions so far as they may be applicable.

ज्ञापन/ MEMORANDUM

(क)	कार्यों का विवरण/ Name of work	तमलम स्थित बैंक के स्टाफ क्वार्टर्स में अधिकारी फ्लैट (E-08) के नवीकरण / Renovation of Officer flat (E-08) at Bank's Staff quarters, Thamalam, Thiruvananthapuram.
(ख)	भुगतान की शर्तें/ Terms of Payment	सामान्य निर्देशों के खंड 32 और परिशिष्ट के अनुसार/ As per clause 32 of the General conditions of contract and Appendix.
(ग)	कार्यों को पूरा करने के लिए अनुमत समय/ Time allowed for completion of work	स्वीकृति पत्र जारी होने के 10 वें दिन से 9 हफ्ते Nine weeks from the 10th day of date of issue of work order
(घ)	अनुमानित लागत/ Estimated Cost	रु 15.00 लाख . (जि.एस. टी के साथ/ ₹15.00 lakh inclusive of GST
(ङ)	अग्रिम धन जमा /ईएमडी/(Earnest Money Deposit (EMD)	Shall be collected from successful bidder @2% of the value of work, on awarding the work

(च)	बिल से प्रतिधारण धन के प्रति कितना प्रतिशत कटौती की जाएगी, यदि कोई हो/ Percentage if any to be deducted from Bill towards Retention Money (R.M)	5% from each bill (Maximum of 5% of contract amount).
-----	--	---

यदि यह निविदा स्वीकृत होती है तो मैं/हम इसके द्वारा यहाँ इसके साथ संलग्न उक्त संविदा की शर्तों और उक्त शर्तों के उपबंधों का पालन करने और उस सीमा तक उन्हें पूरा करने के लिए सहमत हूँ /हैं जहां तक वे लागू हैं अथवा वैसा न कर पाने की स्थिति में उक्त शर्तों में उल्लिखित राशि ज़ब्त किये जाने और भारतीय रिज़र्व बैंक को भुगतान करने के लिए सहमत हूँ।

1. Should this tender be accepted, I/we hereby agree to abide by and fulfill the terms and provisions of the said Conditions of Contract annexed hereto so far as they may be applicable or in default thereof to forfeit and pay to the Reserve Bank of India the amount mentioned in the said conditions.

2. On acceptance of tender, we will deposit a sum @ 2% of value of work as earnest money with RBI on intimation from the Bank about acceptance of the tender, which amount will not bear any interest. Should I/We fail to execute the contract when called upon to do so or fail to adhere to any of the condition given in tender, I/We do hereby agree that this sum shall be forfeited by me / us to RBI.

हमारे बैंकरों के ब्योरे निम्नानुसार हैं/ Our Bankers are:

i)

ii)

भवदीय/Yours faithfully,
संविदाकार के हस्ताक्षर/ Signature of the Tenderer

SECTION B

GENERAL INSTRUCTIONS TO TENDERERS

1. E-tender should be submitted in MSTC portal under RBI Portal for the work of **‘Renovation of Officer flat (E-08) at Bank’s Staff quarters, Thamalam, Thiruvananthapuram’** not later than 3:00 PM on November 07, 2024. Telegraphic, Fax and E-mail tenders shall not be accepted. No tender received after 3:00 PM on November 07, 2024 shall be accepted by MSTC portal.
2. Bidders may contact Banks Engineer to get their doubts clarified. The Bank discourages stipulation of any additional conditions by the tenderers. However, in case the tenderers wish to include any condition / clarification, it shall be separately uploaded in MSTC Portal in their letter head. The clarifications / conditions etc. uploaded if any will be examined and after discussions with all the tenderers, the conditions that are acceptable to the Bank will be intimated to the tenderers. No request for any change in rate or conditions after the opening of the tender will be entertained. However, decision of the Bank on acceptance of conditions put by the bidders is final and binding.
3. Bidders may choose to present for Tender Opening Event in the Bank’s Main Office at scheduled date and time. Tender shall be opened at 4:00 PM on November 07, 2024 or a subsequent date and time, same shall be intimated to the bidders.
4. All information, correspondence letters, shall be submitted in and addressed to Shri Thomas Mathew, Regional Director, Reserve Bank of India, Thiruvananthapuram.
5. Tenders shall remain valid for acceptance by the Bank for a period of three months from the date of opening of the tender which period may be extended by mutual agreement and the tenderer shall not cancel or withdraw the tender during this period.
6. The rates quoted shall be firm and binding without any escalation whatsoever till the completion of the contract. Due to limitation in number of words in price bid in MSTC portal, full description may not be available. However, tenderer shall read all specifications/drawings/conditions from this tender document.
7. For any item, if the rate and amount do not tally with respect to the bill of quantities, then the amount arrived on the basis of quoted rates shall only be considered.
8. Digital Signatures may be used to submit the tender in token of his / their acquainted himself / themselves with the terms and conditions of this tender.
9. If any of the document is missing, the tender may be considered invalid by the Bank at its discretion. No advice of any change in rate or conditions after opening of the tender will be entertained.
10. The vendors shall pay the transaction fee vide the procedures listed in ‘Guidelines for e-procurement’. Transaction fee is non-refundable. A vendor will not have the access to online e-tender without making the payment towards transaction fee.
11. **Successful bidder shall pay as Earnest Money Deposit a sum equivalent to 2% of the value of work through NEFT/ Bank guarantee. The EMD shall not be accepted in any form other than the one mentioned in the tender notice. The EMD shall be forfeited in case the contractor fails to commence the work awarded to her/him within the prescribed time limit. On awarding the work, the successful bidder shall also submit a Performance Bank Guarantee (PBG) for 5% of the accepted Contract Value, valid for**

the Contract Period for due fulfilment of the contractual obligations by the contractor. In case of delay in submission of EMD & PBG due to unavoidable circumstances, charges shall be recovered from the bills of the contractor at Bank's rate.

The EMD and PBG paid by the successful tenderer shall be held by the Reserve Bank of India as Security Deposit (SD) for execution and fulfilment of the contract. No interest shall be paid on this deposit. The Bank will withhold 5% of the total value of work done from their bill/s as Retention Money. The SD (EMD + PBG) shall be released to the contractor on virtual completion and the R.M. shall be released after successful completion of 12 months of Defect Liability Period. The Security Deposit of the successful tenderer and R.M. will be forfeited if he fails to comply with any of the conditions of contract.

12. The Reserve Bank of India does not bind itself to accept, the lowest or any tender and reserve to itself the right to accept or reject any or all the tenders, either in whole or in part, without assigning any reasons for doing so.
13. On receipt of intimation from the Employer of acceptance of his / their tender, the successful bidder shall be bound to implement the contract and within fourteen days thereof the successful bidder shall sign an agreement in accordance with the draft agreement and the Schedule of Conditions but the written acceptance by the Reserve Bank of India of a tender will constitute a binding contract between the Reserve Bank of India and the person so tendering, whether such formal agreement is or is not subsequently executed.
14. All compensation or other sums of money payable by the Contractor to the Employer under the terms of this Contract may be deducted from the Security Deposit if the amount so permits and the Contractor shall, unless such deposit has become otherwise payable, within ten days after such deduction make good in cash the amount so deducted.
15. The Contractor shall not assign the Contract. He shall not sublet any portion of the Contract except with the written consent of the Bank. In case of breach of these conditions, the bank may serve a notice in writing on the contractor rescinding the Contract whereupon the security deposit shall stand forfeited to the Bank.
16. The Contractor shall carry out all the work strictly in accordance with Design and drawings, details, specifications and instructions of the Bank's Engineer. If in the opinion of the Bank's Engineer changes have to be made in the design and with the prior approval in writing of the Employer they desire the Contractor to carry out the same, the contractor shall carry out the same without any extra charge. The Bank's decision in such cases shall be final and shall not be open to arbitration.
17. A Schedule of Probable Quantities in respect of each work and specifications accompany these Instructions to Bidders. The Schedule of Probable Quantities is liable to alteration by omissions, deductions or additions at the discretion of the Bank.
18. The tenderer must obtain for himself on his own responsibility and at his own expenses all the information which may be necessary for the purpose of making a tender and for entering into a contract and must examine the drawings (if any) and must inspect the site of the work and acquaint himself with all local conditions, means of access to the work, nature of the work and all matters appertaining thereto.
19. The rates quoted in the tender shall include all charges for clearing of site before commencement as well as after completion, centring, boxing, staging, planking, plant and equipment, storage sheds, watching and lighting by night as well as day including Sundays and holidays, temporary lines for drawing plumbing and electricity supply arrangements (water

and electricity may be made available at the available sources within the Bank's Premises), protection of the public and safety of walls, buildings and all other erections, matters or things and the Contractor shall take down and remove any or all such centering, scaffolding, staging, etc. as occasion shall require or when ordered so to do and fully reinstate and make good all matters and things disturbed during the execution of work and to the satisfaction of the Bank. The rates quoted shall be deemed to be for the finished work to be measured at site. The rates shall also be firm and shall not be subject to exchange variations, labour conditions, fluctuations in railway freights or any conditions whatsoever.

20. The rates for each item in the tender in MSTC Portal shall be quoted exclusive of GST. Total Amount including GST shall be calculated by the MSTC Portal and the total amount for all the items including the G.S.T will be taken as the total Contract Value. Each invoice / bill shall indicate amongst other things, the contractor's PAN and GST Registration Number. The contract value will also be subject to TDS / Withholding Tax as per statutes. No claim in respect of sales tax, sales tax on works contract, excise duty, customs duty, octroi or other tax, duty or levy, service tax whether existing or in future shall be entertained by the Employer.
21. The quantities in the Schedule of Quantities approximately indicate the total extent of work but may vary to any extent and may even be omitted thus altering the aggregate value of the Contract. However, during actual execution of work, if the quantities of any of the items of work exceeds by more than 25% of the tender quantities, the quantities of such items executed, by the authority of the Bank's Engineer and with the concurrence of the employer, in excess of 25% of the tender quantity, shall be considered as an extra item of work for which the Contractors shall submit fresh rates supported by rate analysis worked on the actual cost basis plus 15% towards establishment charges, contractor's overheads and profit. The rates for all such items of work, being current ones, will not be eligible for price adjustment due to increase or decrease in prices of materials and labour rates as per escalation formula, if any, given in the tender. If any of the items of work is omitted from the accepted tender at the sole discretion of the employer, the contractor shall not be entitled to any claim on this account.
22. Time allowed for carrying out the work as mentioned in the Memorandum shall be strictly observed by the Contractor and it shall be reckoned from the 10th day of issue of written order to commence the work.
23. The work shall throughout the stipulated period of the contract be proceeded with all due diligence and if the Contractor fails to complete the work within the specified period, he shall be liable to pay compensation as defined in Clause 27 of the General Conditions of the Contract. The tenderer shall before commencing the work prepare a detailed work programme which shall be approved by the employer. If the contractor fails to continue the work as per the detail work program or fails to deploy labours as required for the smooth flow of the work, Bank reserves right to cancel the contract agreement entered into.
24. Tenders will be considered only from list of contractors empanelled by the Bank in the trades concerned.
25. The Contractor shall not be entitled to any compensation for any loss suffered by him on account of delays in commencing or executing the work, whatever the cause of delays may be, including delays arising out of modifications to the work entrusted to him or in any sub-contract connected therewith or delays in awarding contracts for other trades of the project or in commencement or completion of such works or in procuring Government controlled or other building materials or in obtaining water and power connections for construction purposes or for any other reason whatsoever and the Employer shall not be liable for any claim in respect thereof. The Employer does not accept liability for any sum besides the tender amount, subject to such variations as are provided for herein.

26. The successful tenderer is bound to carry out any items of work necessary for the completion of the job even though such items are not included in the quantities and rates. Schedule of instructions in respect of such additional items and their quantities will be issued in writing by the Bank's Engineer with the prior consent in writing of the Employer
27. The successful tenderer must co-operate with the other Contractors appointed by the Employer so that the execution of work shall proceed smoothly with the least possible delay and to the satisfaction of the Bank's Engineer
28. The Contractor must bear in mind that all the work shall be carried out strictly in accordance with the Specifications, design drawings made by the Bank and also in compliance of the requirements of the local public authorities and to the requirements of the Bank and no deviation on any account will be permitted. Quality of the work should be satisfactory to the bank as per work specifications. Contractor shall make good the bank for any low quality of work executed.
29. The successful tenderer should make his own arrangement to obtain all materials required for the work. The materials as far as procurable shall be first / premium quality conforming to relevant Indian standards.
30. The successful tenderer is bound to purchase the required materials for which the "Basic Price" has been stipulated in the item from the manufacturer approved and selected by the Bank and at the rate approved by the Bank from time to time.
31. **Wherever basic rate for the materials is specified, the contractor should produce 3/4 samples of materials for selection and the purchase rate for the selected items shall be got approved from the Bank's Engineer before purchasing such materials. The basic price of materials shall be taken as cost of material at dealer's ex-godown price excluding GST. If there is any difference in cost of materials selected with basic rate specified in the tender, such difference shall be adjusted while making payment to the Contractor. The adjustment in price of the materials shall be made on measured quantity only. Contractor's profit of 15% shall be allowed on such difference. The contractor should provide to the Bank for verification, paid bills of all purchased materials for ascertaining the actual rate of purchase so as to settle the difference in cost of materials.**
32. The tenderer shall have to use materials of the makes / manufacturers specified in the list of material of approved brand and / or manufacture contained in the e-tender clauses.
33. Electricity and water shall be provided free of cost for execution of the work at one point within the premises. Contractor shall make their own arrangements for conveying the same to the required locations. The contractor shall, however, take care to ensure that no undue wastage of electricity & water is caused. Necessary safety measures shall be taken by the contractor to avoid any mishap. The contractor shall be penalized by the Bank if any laxity on his part is observed in this matter.
34. The Contractor shall strictly comply with the provisions in the Safety & Fire Safety Codes annexed hereto.
35. IS Code numbers wherever mentioned in the tender shall be the latest version as on the date of opening of tenders.
36. Total Security Deposit of successful tenderer will be forfeited if he / they fail to comply with any conditions of the Contract.
37. Errors, Omission and Descriptions:-
 - a) Between the description of the item in the General Specifications and the detailed descriptions in the Schedule of Quantities of the same item, the later shall be adopted.
 - b) In case of difference between the rates mentioned in figures and words, the rate adopted for working out the total amount of item in the original tender form, shall be taken as correct. In all other cases the correct rate would be that which is lower.

38. Clarifications if any with respect to General Conditions, Special Conditions, Scope of work, specifications, design & drawings or any other matter required for submitting the tender shall be obtained from the Bank during working hours of the Bank, before submitting the tenders. Once a tender is submitted, the matter will be decided according to conditions in the tender in the absence of such authentic pre-clarification.
39. The contractor shall abide by and fulfil all requirements laid down under various provisions of Contract Labour (Regulation and Abolition) Act, 1970 and the rules framed there-under. The contractor shall submit to the Bank the maximum number of Labours to be engaged on a single day in the job. Any subsequent increase should be informed to the Bank without delay, if the number of labourers employed for the job are twenty or more, the contractor shall obtain the license from the Regional Labour Commissioner. The contractor should ensure payment of minimum wages to all labourers / workmen staff employed by him and maintain record of labours employed for the work.
40. Contractor should ensure that the instructions/ directions issued by Central as well as State Government, and also by the Bank in connection with Covid-19 Pandemic are followed scrupulously by the workmen deployed at the Bank. Workmen from containment area or under quarantine should not be deployed for work. Further, you are required to closely monitor the staff deployed to the Bank and in case of any staff/family member of staff is found 'Covid' infected, action to be taken to replace the staff at once. Staff should be sensitised to follow strict social distancing norms while they remain deployed. You shall provide them with necessary gloves, masks, sanitizer, etc., at no extra cost to the Bank. Further, you shall indemnify and keep indemnified the Bank from any financial/ legal liability arising out of your failure, fault or negligence in complying-with the above instructions. Any hindrance to the work due to COVID-19 pandemic or any other reasons shall be intimated to the bank's engineer.

I / We hereby declare that I / we have read and understood the above instructions for guidance of tenderers and accept the same.

Date :

Signature of Authorized signatory with seal.

Place :

Name and Address:

GENERAL CONDITIONS OF CONTRACT

The Conditions Hereinbefore Referred To

1. In constructing these conditions, the specification, schedule of quantities and Contract Agreement, the following words shall have the meaning herein assigned to them except where the subject or context otherwise requires.

- | | |
|--|---|
| a) "Employer" | Shall mean the Regional Director, Reserve Bank of India, Thiruvananthapuram and shall include its assigns and successors. |
| b) "Contractor" In the case of company | "Contractor shall mean _____ a company incorporated under _____ 19__ / 20__ and having its registered office at _____ and shall include its successors and assigns. |
| c) "Banks Engineer" | Shall means the person appointed by the Employer to act as Bank's Engineer for the purpose of the contract and named as such in the conditions. [AM (Tech)/ Manager (Tech)/ AGM (Tech)]. |
| d) "Site" | Shall mean the site of the contract works including any building and erection thereon and any other land (inclusively) as aforesaid allotted by the Employer for the Contractor's use. |
| e) "This Contract" | Shall mean the Article of Agreement, the special conditions, the conditions, the Appendix, the schedule of quantities and specifications, design drawings attached hereto and duly signed. |
| f)"Specifications" | Means the specification of the works included in the Contract and any modification thereof or addition thereto made or submitted by the Contractor and approved by the Engineer. |
| g)"Notice in writing" | Shall mean a notice in written, typed or printed or written notice" characters sent (unless delivered personally otherwise proved to have been received) by registered post to the last known private or business address or registered office of the addressee and shall be deemed to have been received when in the ordinary course of post it would have been delivered. |
| h) "Bill of Quantities" | Means the priced and completed bill of quantities forming the part of Tender |
| i)"Tender" | Means The Contractor's priced offer to the Employer for the execution and completion of the works and remedying of any defects therein in accordance with the provisions of the contract, as accepted by the letter of acceptance. |

- j) "Letter of acceptance" Means the formal acceptance by the employer of the tender
- k) "Act of Insolvency" Shall mean any Act of insolvency as defined by the Presidency Town Insolvency Act, or the provincial insolvency Act or any Act amending such original Act.
- l) "Net Prices" If in arriving at the contract amount the Contractor shall have added to or deducted from the total of items in the Tender any sum, either as a percentage or otherwise, then net price of any item in their tender shall be the sum arrived at by adding to or deducting from the actual figures appearing in the Tender as the price of that the item a similar percentage or proportionate sum provided always that in determining the percentage or proportion of the sum so added or deducted by the Contractor the total amount of the any Prime Cost items and provisional sums of money shall be deducted from the total amount of the tender. The expression "net rates" or "net prices" when used with reference to the contract or account shall be held to mean rates or prices so arrived at.
- m) "The works" Shall mean 'Renovation of Officer flat (E-08) at Bank's Staff quarters, Thamalam, Thiruvananthapuram' as provided herein

Note: Words imparting persons include firms and corporations. Words imparting the singular only also include the plural and vice versa where the context requires.

2. **Scope of Contract:** The contractor shall carry out and complete the said work in every respect in accordance with this contract and with the directions of and to the satisfaction of the Bank's Engineer. The Bank's Engineer may in his absolute discretion and from time-to-time issue further drawings and/or written instructions, details, direction and explanations which are hereafter collectively referred to as "Bank's Engineer's instruction in regard to":

- a) The variations or modifications of the design, quality or works or the addition or omission or substitutions of any work.
- b) Any discrepancy in the Drawing or between the Schedule of Quantities and/or Drawing and/or specifications.
- c) The removal from the site of any materials brought thereon by the contractor and the substitution of any other material therefor.
- d) The removal and/or re-execution of any works executed by the contractor.
- e) The dismissal from the works of any persons employed thereupon.
- f) The opening up for inspections of any work covered up.
- g) The amending and making good of any defects under clause 20 & 21 hereof.

The contractor shall forthwith comply with and duly execute any work comprised in such Bank's Engineer's instructions provided always that verbal instructions, directions and explanations given to the Contractor or his representative upon the works by the Bank's Engineer shall, if involving a variation, be confirmed in writing by the Contractor within seven days, such shall be deemed to be Employer's instructions within the scope of the Contract.

3. **Variations to be approved by the Employer:** The contractor shall submit a statement of variations giving quantity and rates duly supported by analysis of rates, vouchers etc. The rates on scrutiny and final acceptance by the Employer shall form a supplementary tender. Minor alterations (of the order of a few centimetres) as per site conditions may be carried out during execution with respect to the drawings. The Employer shall not be liable for payment of such variations until these statements are sanctioned by him.
4. **Drawings, Schedule of Quantities:** The Contract shall be executed in duplicate and the Bank's Engineer, the Employer and the Contractor shall be entitled to one executed copy of each for his use. The Contractor on the signing hereof shall be furnished by the Bank's Engineer free of cost one copy of each of the said Drawings (if any) and of the specification and one copy of all further Drawings (if any) issued during the progress of the works. Any further copies of such Drawings required by the Contractor shall be paid for by him. The contractor shall keep one copy of all Drawings on the works and the Bank's Engineer, or his representative shall at all reasonable times have access to the same. Before the issue of the final certificate to the Contractor he shall forthwith return to the Bank's Engineer all Drawings and Specifications.
5. **Contractor to provide everything necessary at his cost:** The contractor shall provide at his cost everything necessary for the proper execution of the work according to the intent and meaning of the drawing. Schedule of quantities and specification taken together with whether the same may or may not be particularly shown or described therein provided that the same can reasonably be inferred there from and if the contractor finds any discrepancy in the drawings or between the drawings schedule of quantities and specifications he shall immediately and in writing refer same to the Bank's Engineer who shall decide which is to be followed. Between drawings and specifications/ schedule of Quantities, schedule of quantities will prevail.
6. **Authorities, notices and patents:** The contractor shall conform to the provisions of any Act of the legislature relating to the works and to the regulations and bye-laws of any authority, and of any water, electric supply and other companies and / or authorities with whose, systems the structure is proposed to be connected, and shall, before making any variations from the drawings (if any) or Specifications that may be necessitated by so conforming, give to the Bank's Engineer written notice, specifying the variation proposed to be made and the reason for making it and apply for instruction thereon. In case the Contractor shall not within ten days receive such instructions, he shall proceed with the work conforming to the provisions, regulations, or by-laws in question, and any variation so necessitated shall be dealt with under Clause 18 thereof.

The contractor shall bring to the attention of the Employer all notices required by the said Acts, regulations or bye-laws to be given to any authority and pay to such authority or to any public office all fees that may be properly chargeable-in respect of the works and lodge the receipts with the Employer.

The Contractor shall indemnify the Employer against all claims in respect of patent rights and shall defend all actions arising from such claims and shall himself pay all royalties, license fees, damages cost and charges of all and every sort that may be legally incurred in respect thereof.
7. **Setting out of work:** The Contractor shall set out the works and shall be responsible for the true and perfect setting out of the same and for the correctness of the positions, levels, dimensions, and alignment of all parts thereof and got approved prior to proceeding of the work. If the contractor fails in their role, any errors/defects shall be rectified at his own expense to the satisfaction of the Bank/ Employer
8. **Materials and Workmanship to conform to description:** All materials and workmanship shall so far as procurable be of the respective kinds described in the Schedule of Quantities and/or Specifications and in accordance with the Bank's Engineer's instructions, and the Contractor shall upon the request of the Bank's Engineer furnish him with all invoices, accounts, receipts and other vouchers to prove that the materials comply therewith. The

Contractor shall at his own cost arrange for and/or carry out test of any materials as per relevant IS provisions through the reputed laboratories prior to use in the work.

9. **Contractor's superintendence and representative on the works**: The Contractor shall give all necessary personal superintendence during the execution of the works, and as long thereafter as the Bank's Engineer may consider necessary until the expiry of the "Defects Liability Period" stated in the Appendix hereto. The Contractor shall also during the whole time the works are in progress employ a competent, qualified and experienced Engineer who shall be constantly in attendance at the works while the men are at work. Any directions explanation, instructions or notices given by the Bank's Engineer to such representative shall be held to be given to the Contractor.
10. **Dismissal of workmen**: The Contractor shall on the request of the Bank's Engineer immediately dismiss from the works any person employed thereon by him who may, in the opinion of the Bank's Engineer, be incompetent or misconduct himself and such persons shall not be again employed on the works without the permission of the Consultant.
11. **Access to works**: The Employer, the Bank's Engineer and their respective representatives shall at all reasonable times have free access to the work and / or to the workshops, factories or other places where materials are lying or from which they are being obtained and the Contractor shall give every facility to the Employer, the Bank's Engineer and their representatives necessary for inspections and examination and test of the materials and workmanship. No person not authorized by the Employer or the Bank's Engineer except the representatives of public authorities shall be allowed on the works at any time.
12. **Assistant Manager (Tech.)/ Manager (Tech)**: The term "Assistant Manager (Tech)/ Manager (Tech.) shall mean the person appointed and paid by the Employer to inspect the works. The Contractor shall afford the Assistant Manager (Tech.) every facility and assistance for inspecting the works and materials and for checking and measuring time and materials.

The Assistant Manager (Tech.)/ Manager (Tech.), or the Employer shall have power to give notice to the Contractor or to his representative of non-approval or any work or materials and such work shall be suspended, or the use of such materials shall be discontinued. The work will from time to time be examined by the Assistant Manager (Tech.) but such examination shall not in any way exonerate the Contractor from the obligation to remedy any defects, which may be found to exist at any stage of the works or after the same is completed. Subject to the limitations of this clause the Contractor shall take instructions only from the Bank's Engineer.
13. **Assignment and Subletting**: The whole of the works included in the Contract shall be executed by the Contractor and the contractor shall not directly or indirectly transfer, assign or under-let the Contract or any part share thereof or any interest therein without the prior written consent of the Employer and not undertaking shall relieve the Contractor from the full and entire responsibility of the Contract or from active superintendence of the works during their progress.
14. **Alterations, additions, omissions etc.**: No alteration, omission or variation shall vitiate this contract except instructions/ notice of Employer (through Bank's Engineer) at any time during the progress of the works to make any alterations in, or addition to, or omissions from the works or any alteration in the kind of quality of the materials to be used therein and shall give notice thereof in writing under its hand to the Contractor. The Contractor shall alter, add to, or omit from, as the case may be, in accordance with such notice, but the contractor shall not do any work extra to or make any alterations or additions to or omissions from the works or any deviation from any of the provisions of the Contract. Stipulations, specifications or Contract Drawings without the previous consent in writing of the Employer and the value of such extra alterations, additions or omission shall, in all cases, be determined by the Employer in

accordance with the provisions of Clause 18 hereof, and the same shall be added to, or deducted from the Contract Amount, as the case may be accordingly.

15. **Schedule of Quantities**: The Schedule of quantities, unless otherwise stated shall be deemed to have been prepared in accordance with the Standard Method of Measurement specified in relevant IS code.

Any error in description or in quantity or in omission of items from the schedule of quantities shall not vitiate this contract but shall be rectified and the value thereof, as ascertained under Clause 17 hereof, shall be added to, or deducted from the Contract Amount (as the case may be) provided that no rectification of errors, if any, shall be allowed in the Contractor's schedule of rates.

16. **Sufficiency of Schedule of Quantities**: The Contractor shall be deemed to have satisfied himself before tendering as to the correctness and sufficiency of his tender for the works and of the prices stated in the Schedule of Quantities and/or the schedule of rates and prices which rates and prices shall cover all his obligations under the contract, and all matters and things necessary for the proper completion of the works.

17. **Measurement of works**: The Bank's Engineer may, from time to time, intimate to the contractor that he requires the works to be measured, and the Contractor shall forthwith attend or send a qualified agent to assist Assistant Manager (Tech) in taking such measurements and calculations and to furnish all particulars or to give all assistance required by any of them. Should the Contractor not attend or neglect or omit to send such agent then the measurement taken by the Bank's Engineer or a person approved by him shall be taken to be correct measurement of the works. Such measurements shall be taken in accordance with the Method of Measurements detailed in the latest relevant IS Codes of practice.

The Contractor or his Agent may at the time of measurement take such notes and measurement as he may require.

All authorized extra works, omissions and all variations made with the Bank's Engineer's instructions, subsequently conveyed in writing (with the prior approval in writing of the Employer) shall be included in such measurements.

18. **Prices for extra etc. ascertainment of**: The Contractor may, when authorized and shall, when directed, in writing by the Employer, add to, omit from or vary the works shown upon the drawings, or described in the specification, or included in the schedule of Quantities, but the contractor shall make no addition, omission or variation without such authorization or direction. A verbal authority or direction by the Bank's Engineer shall, if confirmed by them in writing within seven days, be deemed to have been given in writing.

However, during actual execution of work if the quantities of any of the items of work exceeds by more than 25% of the tender quantities, the quantities of such items executed, by the authority of the Architects of the project band with the concurrence of the employer in excess of 25 % of the tender quantity shall be considered as an extra item of work for which the contractors shall submit fresh rates supported by rate analysis worked on the actual cost basis plus 15% towards establishment charges, contractor's overhead and profit. The rates for all such items of work, being current ones, will not be eligible for price adjustment due to increase or decrease in prices of materials and labour rates as per escalation formula, if any, given in the tender. If any of the items of work is omitted from the accepted tender at the sole discretion of the employer, the contractor shall not be entitled to any claim on this account.

No claim for an extra shall be allowed unless it shall have been executed under provisions of clause 5 hereof with the concurrence of the Employer herein mentioned. Any such extra in herein referred to as authorized and shall be made in accordance with the following provisions.

- (a) (i) The net rates or prices in the original tender shall determine the valuation of the extra work where such extra work in similar character and executed under conditions as the work priced therein.

- (ii) Rates for all items, wherever possible should be derived out of the rates given in the priced Schedule of Quantities.
- (b) The net prices of the original tender shall determine the value of items omitted provided if omissions vary the conditions under which any remaining items of works are carried out, the prices for the same shall be valued under sub-clause(c) hereof.
- (c) Where the extra works are not of similar character and/or quoted under similar conditions as aforesaid or where the omissions vary the conditions under which any remaining items of works are carried out or if the amount of any omissions or additions relative the amount of the whole of the Contract works or to any part thereof shall be such that in the opinion of the Bank's engineer, the net rate or price contained in the priced Schedule of Quantities or tender or for any item of the works involves loss or expenses beyond that reasonably contemplated by the contractor or is by reason of such omission or addition rendered unreasonable or inapplicable, the Bank's Engineer shall fix such other rate or price as in the circumstances he shall think reasonable and proper, with the prior approval in writing of the Employer.
- (d) Where extra work cannot be properly measured or valued, the Contractor shall be allowed day work prices as the net rates stated in the tender or the Priced Schedule or Quantities or, if not so stated, then in accordance with the local day work rates and wages for the district provided that in either case vouchers specifying the daily time (the workmen's names) and materials employed be delivered for verification to the Bank's Engineer at or before the end of the week following that in which the work has been executed. The measurement and valuation in respect of the Contract shall be completed within the "period of final measurements".
- (e) It is further, clarified that for all such authorized extra items where rates cannot be derived from tender, the contractor shall submit rates, supported by rate analysis worked out based on CPWD schedule of rate analysis or for items not available in CPWD schedule, based on market rate with "actual cost basis", plus 15% towards establishment charges, contractor's overheads and profit. Such items will not be eligible for escalation.

19. Unfixed materials when taken into account to be the property of the Employer

Where in any certificates (of which the Contractor has received payment) the Bank's Engineer has included the value of any unfixed materials included for and/or placed on or adjacent to the works such materials shall become the property of the Employer and they shall not be removed except for use upon the works, without the written authority of the Employer. The Contractor shall be liable for any loss of, or damage to, such materials.

20. **Removal of improper work** : The Employer shall, during the progress of the works, have power to order in writing from time to time the removal from the works within such reasonable time or times as may be specified in the order of any materials which in the opinion of the Bank's Engineer are not in accordance with the Specifications, the substitutions of proper materials, and the removal and proper re-execution of any work executed with materials or workmanship not in accordance with the drawings (if any) & specifications or instructions and the contractor shall forthwith carry out such order at his own cost. In case of default on the part of Contractor to carry out such order, the Employer shall have the power to employ any pay other persons to carry out the same; and all expenses consequent thereon, or incidental thereto, shall be borne by the Contractor, or may be deducted by the Employer from any moneys due, or that may become due, to the Contractor.
21. **Defects after virtual completion** : Any defect, shrinkage, settlement or other fault which may appear within the "Defects Liability Period" stated in the Appendix hereto, or, if none stated them within twelve months after the virtual completion of the works, arising in the opinion of the Employer from materials of workmanship not in accordance with the contract, shall upon the direction in writing of the Employer, and within such reasonable time as shall be specified

therein, be amended and made good by the Contractor, at his own cost and in case of default the Employer may employ and pay other persons to amend and make good such defects, shrinkage settlements or other faults, and all damages loss and expenses consequent thereon are incidental thereto shall be made good and borne by the Employer or may be deducted by the Employer, upon the Bank's Engineer's Certificate in writing, from any money due or that may become due to the Contractor, or the Employer may in lieu of such amending and making good by the Contractor deduct from any money due to the Contractor a sum, to be determined by the Employer equivalent to the cost of amending such work and in the event of the amount retained under clause 32 hereof being insufficient, recover the balance from the Contractor, together with any expenses the Employer may have incurred in connection therewith. Should any defective work have been done or materials supplied by any sub-contractor employed on the works who has been nominated as provided under clause 13 and 23 hereof, the contractor shall be liable to make good in the same manner as if such work or material had been done or supplied by the Contractor and been subject to the provision of this clause and clause 2 hereof. The contractor shall remain liable under the provisions of the clause notwithstanding the signing of any certificate or the passing of any accounts by the Employer.

22. **Certificate of virtual completion and defects liability period:** The works shall not be considered as completed until the Bank's Engineer has certified in writing that they have been virtually completed. The defects liability period shall commence from the date of virtual completion.
23. **Nominated Sub-Contractor:** All Specialists, Merchants, Tradesmen and others executing any work of supplying and fixing any goods for which the prime cost prices or provisional sums are included in the Schedule of Quantities and/or Specifications who may be nominated or selected by the Employer or hereby declared to be sub-contractors employed by the contractor and are herein referred to as nominated sub-contractors.

No nominated sub-contractors shall be employed on or in connection with the works against the Contractor shall make reasonable objection are (save where the Architect and the Contractor shall otherwise agree) who will not enter into contract providing.

- (a) That the nominated sub-contractor shall indemnify the contractor against the same obligation in respect of the sub-contract as the contractor is under in respect of this contract.
 - (b) That the nominated sub-contractor shall indemnify the contractor against claims in respect of any negligence by the sub-contractors his servants or agents or any misuse by him or them or any scaffolding or other plant, the property of the Contractor or under any Workmen's Compensation Act in force.
 - (c) Payment shall be made to the nominated sub-contractor within fourteen days of his receipt of the Employer's Certificate provided that before any Certificate is issued the Contractor shall upon request furnish to the Bank proof that all nominated sub-contractors accounts included in previous certificates have been duly discharged; in default whereof, the Employer may pay the same upon a Certificate of the Bank and deduct the amount thereof from any sums due to the Contractor. The exercise of this power shall not create private of contract as between Employer and Sub-Contractor.
24. **Other persons employed by Employer:** The Employer reserves the right to use premises and any portion of the site for the execution of any work not included in this Contract which it may desire to have carried out by other persons, and the Contractor shall allow all reasonable facilities for the execution of such work but shall not be required to provide any plant or material for the execution of such work except by special arrangement with the Employer. Such work shall be carried out in such manner as not to impede the progress of the works included in the Contract and the Contractor shall not be responsible for any damage or delay which may happen to or occasioned by such work.

25. **Insurance in respect of damage to person and property**: The Contractor shall be responsible for all injury or damage to persons, animals or things and for all damage to property which may arise from any factor omission on the part of the Contractor or any Sub-Contractor or any nominated Sub-Contractor or any of their employees. The liability under this clause shall cover also, inter-alia any damages to structures, whether immediately adjacent to the works or otherwise; any damage to roads, streets, footpaths, bridges as well as damage caused to the buildings and other structures and works forming the subject matter of this contract. The contractor shall also be responsible for any damage caused to the building and other structures and works forming the subject, matter of this contract due to rain, wind, frost or other inclemency of weather. The contractor shall, indemnify and keep indemnified the Employer and hold him harmless in respect of all and any loss and expenses arising from any such injury or damage to persons or property as aforesaid and also against any claim made in respect of injury or damage, whether under any statute or otherwise and also in respect of any award or compensation or damage consequent upon such claims.

The Contractor shall, at his own expense, effect and maintain till issue of the virtual completion certificate under this contract, with an insurance company approved by the Employer, an **All Risk Policy** for Insurance for the full amount of the contract in the joint names of the employer and the contractor (the name of the former being placed first in the policy) against all risk policy for contractors and deposit such policy or policies with the employer before commencing the works.

The Contractor shall also indemnify and keep indemnified the Employer against all claims which may be made against the Employer by any person in respect of anything which may arise in respect of the works or in consequence thereof and shall at his own expense, effect and maintain until the virtual completion of the contract, with an Insurance Company approved by the employer a policy of Insurance in the joint names of the Employer and the Contractor (name of the former being placed first in the policy) against such risk and deposit such policy or policies before commencement of the works. The minimum limit of the coverage under the policy shall be Rs. 2 lakh per person for any one accident or occurrence and Rs. 5 lakh in respect of damage to property for any one accident or occurrence subject to an overall ceiling of Rs 10 lakh. The contractor shall also indemnify the employer against all claim which may be made upon the Employer, whether under the **Workmen's Compensation Act** or any other statute in force, during the currency of this contract or at Common Law in respect of any employee of the contractor or of Sub-Contractor and shall at his **own expense** effect and maintain until the virtual completion of the contract or with an Insurance Company, approved by the Employer, a policy of insurance against such risks and deposit such policy or policies with the Employer from time to time during the currency of this contract.

In default of the contractor insuring as providing above, the employer may so insure and may deduct the premiums paid from any moneys due or which may become due to the contractor. The contractor shall be responsible for any liability which may not be covered by the Insurance Policies referred to above and also for all other damages to any person, animal or defective carrying out of this contract, whatever, may be the reasons due to which the damage shall have been caused.

The contractor shall also indemnify and keep Indemnified the Employer against all and any costs, charges or expenses arising out of any claim or proceedings relating to the works and also in respect of any of damage or compensation arising there from.

Without prejudice to the other rights of the employer against contractor in respect of such default, the employer shall be entitled to deduct from any sums payable to the contractor the amount of any damages, compensation costs, charges and other expenses paid by the employer and which are payable the contractor under this clause.

The Contractor shall upon settlement by the insurer pursuant to a policy taken under this clause, proceed with due diligence to re-build or repair the works destroyed or damaged. In this event all the monies received from the Insurer in respect of such damage shall be paid to the Contractor and the contractor shall not be entitled to any further payment in respect of the

expenditure incurred for re-building or repairing of the materials or goods destroyed or damaged.

The contractor, in case of re-building or reinstatement after damage shall be entitled to such extension of time for completion as the Bank's Engineer may deem fit, but shall, however, not be entitled to reimbursement by the employer of any shortfall or deficiency in the amount finally paid by the insurer in settlement of any claim arising as set out herein.

Without prejudice to his liability under this clause, the contractor shall also cause all nominated sub-contractors to effect, for their respective portions of the works, similar policies of insurance in accordance with the provisions of this clause and shall produce or cause to produce to the employer such policies. The contractor shall not permit a nominated sub-contractor to commence work at the site unless the said insurance policies are submitted. In the event of failure of the sub-contractor to take out such a policy of insurance before commencing the works at the site, the contractor shall be responsible for any claim or damage attributable to the said sub-contractor

The Contractor shall at his own expense, arrange to effect and maintain (until the virtual completion of the contract) with an approved office, the following insurance policies in the joint name of employer and himself with the employer being first (Principal) and deposit such policy or policies with the employer from time during the currency of this contract.

a) Workmen compensation policy. b) CAR Policy c) Third party liability policy

26. **Date of commencement and completion**: The Contractor shall be allowed admittance to the site on "Date of Commencement" stated in the Appendix hereto, or each later date as may be specified by the Employer and he shall thereupon and forthwith begin the works and shall regularly proceed with and complete the same (except such painting or other decorative work as the bank may desire to delay) or before the "Date of Completion" stated in the Appendix subject nevertheless to provisions for extension of time hereinafter contained.
27. **Liquidated damages for non-completion**: If the Contractor fails to complete the works by the date stated in the Appendix or within any extended time under Clause 28 here the Contractor shall pay the Employer the sum named in the Appendix as " Liquidated Damages" for the period during which the said works shall so remain incomplete and the Employer may deduct such damages from any money due to the Contractor.
28. **Delay and extension of time**: If in the opinion of the Employer the works be delayed (a) by force majeure or (b) by reason of any exceptionally inclement weather or c) by reason of proceedings taken or threatened by or dispute with adjoining or neighbouring owners or public authorities arising otherwise than through contractor's own default or (d) by the works or delays of other contractor or Tradesmen engaged or nominated by the Employer and not referred to in the schedule of quantities and/or specifications or (e) by reasons of Bank's Engineer instruction as per clause 2 hereof (f) by reason of civil commotion, local combination of workmen or strike or lockout affecting any of the building trades or (g) in consequence of the Contractor not having received in due time necessary instructions from the Bank for which he shall have specifically applied in writing or (h) from other causes which the Bank may certify as beyond the control of contractor or (i) in the event, the value of the work exceed the value of the Priced Schedule of Quantities owing to variation, the Bank may make a fair and reasonable extension of time for completion shall as soon as may be given written notice thereof to the bank but the Contractor shall nevertheless constantly use his endeavours to prevent delay and shall do all that may reasonably has required to the satisfaction of Bank to proceed with work. Decision of the bank if delay is due to force majeure or not shall be final and binding on the contractor.
29. **Contractor's failure to comply with Employer's instruction**: If the Contractor after receipt of written notice from the Employer requiring compliance within 10 days fails to comply with

such further drawings and/or Bank's instructions the Employer may employ and pay other persons to execute any such work whatsoever that may be necessary to give effect thereto, and all costs incurred in connection therewith shall be recoverable from the Contractor by the Employer as a debt or may be deducted by him from any moneys due to the Contractor.

30. **Termination of Contract by the Employer:** If the Contractor being an individual or a firm commits any "act of insolvency" or shall be adjudged an insolvent or being an incorporated company shall have an order for compulsory winding up made against it or pass an effective resolution for winding up voluntarily or subject to the supervisions of the court and the Official Assignee or the Liquidator in such acts of insolvency or winding up, as the case may be, shall be unable within seven days after notice to him requiring him to do so to show the reasonable satisfaction of the Employer that he is able to carry out and fulfil the Contract and to give security therefore, if so required by the Employer.

Or if the Contractor whether an individual, first or incorporated company shall suffer execution or other process of court attaching property to be issued against the Contractor.

Or shall suffer any payment under this contract to be attached by or on behalf of any of the creditors of the Contractors.

Or shall assign to sublet this Contract without the consent in writing of the Employer first had and obtained.

Or shall charge or encumber this Contract or any payments due or which may become due to the Contractor hereunder.

Or if the Bank's Engineer shall certify in writing that the Contractor,

- (i) Has abandoned the Contract, or
- (ii) Has failed to commence the works, or has without any lawful excuse under these conditions suspended the progresses of the works for fourteen days after receiving from the Bank notice to proceed or
- (iii) Has failed to proceed with the work with such due diligence and failed to make such due progress as would enable the works to be completed within the time agreed upon, or
- (iv) Has failed to remove materials from the site or to pull down and replace work for seven days receiving from the Bank written notice that the said materials or work were condemned and rejected by the Bank's Engineer under these conditions' or
- (v) Has neglected or failed persistently to observe and perform all of any of the acts, matter or things by the Contract to be observed and performed by the Contractor for seven days after written notice shall have been given to the Contractor requiring the Contractor to observe or perform the same.

Then and in any of the said cases the Employer may, notwithstanding any previous waiver, after giving seven days' notice in writing to the Contractor, determine the contract, the whole of which shall continue in force as fully as if the Contract has not been so determined, and so if the works subsequently execute had been executed by or on behalf of the Contractor. And further, the Employer by his agents or servants may enter upon and taken possession of the works and all plant, tools scaffoldings, sheds, machinery, steam and other power utensils and materials lying upon the premises or the adjoining lands or roads, and use the same as his own property or may employ the same by means of his own servants and workmen in carrying on and completing the work or by employing any other Contractor or other person or persons to complete the works, and the Contractor shall not in any way interrupt or do any act matter

or thing to prevent or hinder such other contractor or other person or persons employed for completing and finishing or using the materials and plant for the works. When the works shall be completed or as soon thereafter as convenient the Bank shall give a notice in writing to the Contractor to remove his surplus materials and plant, and should the Contractor fail to do so within a period of fourteen days after receipt thereof by him, the Employer may sell the same by public auction, and give credit to the Contractor for the net amount realized. The employer shall thereafter ascertain and certify in writing under his hand what of the said plant and materials so taken possessions or by the Employer and the expenses or loss which the Employer shall have been put to in procuring the works to be completed and the amount. If any, owing the Contractor and the amount which shall be so certified shall thereupon be paid by the Employer to the Contractor or by the Contractor to the Employer, as the case may be, and the Certificate of the Bank shall be final and conclusive between the parties.

31. **Termination of Contract by Contractor:** If this payment of the amount payable by the Employer under Certificate of the Bank's Engineer shall be in arrears and unpaid for thirty days after notice in writing requiring payment of the amount as aforesaid shall have been given by the Contractor to the Employer, or if the Employer interferes with or obstructs the issue of any such Certificate, or if the Employer shall repudiate the Contract, or if the works be stopped for three months under the order of the Architect or the Employer or by any injunction or other order of any court of Law, then and in any of the said cases the Contractor shall be in liberty to terminate the Contract by notice in writing to the Employer, and he shall be entitled to recover from the Employer, payment for all works executed and for any loss he may sustain upon any plant or materials supplied or purchased or prepared for the purpose or the Contract.

In arriving at the amount of such payment the net rates contained in the Contractor's original Tender shall be followed or where the same may not apply valuation shall be made in accordance with Clause 18 hereof.

32. **Certificates and Payments:**

- a. The Contractor shall be paid by the Employer from time to time by instalments under Interim Certificates to be issued by the Bank's Engineer to the Contractor on account of the works executed when in the opinion of the Bank's Engineer, work to the approximate value named in the Appendix as 'Value of work for Interim Certificates' (or less at the reasonable discretion of the Bank's Engineer) has been executed in accordance with this Contract, subject, however, to a retention of the percentage of such value named in the Appendix hereto as 'Retention Percentage for Interim Certificates' until the total amount retained shall reach the sum named in Appendix as 'Total "Retention Money' after which time instalments shall be up to the full value of the work subsequently so executed and fixed in the building. The Bank's Engineer may in his discretion include the Interim Certificate such amount as he may consider proper on account of materials delivered upon the site by the Contractor for use in the works. And when the works have been virtually completed and the Bank's Engineer shall have certified in writing that they have been completed, the Contractor shall be paid by the Employer in accordance with the Certificate to be issued by the Bank's Engineer the sum of money named in the Appendix as 'Instalment after Virtual Completion' being a part of the said Total Retention money. And the Contractor shall be entitled to the payment of the final balance in accordance with the Final Certificate to be issued in writing by the Bank's Engineer at the expiration of the period referred to as the 'Defect Liability Period' in the Appendix hereto from the date of Virtual Completion or as soon as after the expiration of such period as the works shall have been finally completed and all defect made good according to the true intent and meaning hereof whichever shall last happen, provided always that the issue by the Bank's Engineer of any Certificate during the progress of the works or at or after their completion shall not relieve the contractor from his liability under Clause 2 and 21, in cases of fraud, dishonesty, or fraudulent concealment

relating of the works or material or to any matter dealt with in the Certificate, and in case of all defects and insufficiencies in the works or materials which a reasonable examination would not have disclosed. No certificate of the Bank's Engineer shall of itself be conclusive evidence that any works or materials to which it relates are in accordance with the Contract neither will the Contractor have a claim for any amounts which the Bank's Engineer might have certified in any interim bill and paid by the Employer, and which might subsequently be discovered as not payable and in this respect the Employer's decision shall be final and binding.

- b. The Bank's Engineer shall have power to withhold any Certificate if the works or any parts thereof are not being carried out to his satisfaction.
- c. The Bank's Engineer may make any correction in any previous Certificate which shall have been issued by him.
- d. No certificate of payment shall be issued by the Bank's Engineer if the Contractor fails to insure the work and keep them insured till the issue of the Virtual Completion Certificate.
- e. Payment upon the Bank's Engineer's Certificate shall be made within the periods named in the Appendix as 'Period for honour of Certificates' after such Certificates have been delivered to the Employer

The following terms of payment only are applicable for the work.

Payments for the value of work done by the contractor will be made by the Bank after successful completion of the work based on the certificate issued by the Bank's Engineer. The total amount payable to the contractor shall be paid as '**First and Final Bill**' on completion of the entire work after effecting statutory deductions. All payment shall be subject to recovery of 5% towards Retention Money & TDS as per the statutory requirements.

33. **Delayed Payment:** Any amounts payable by the Employer to the Contractor shall, if not paid within the 'period of honouring certificates' named in the Appendix carry interest at the rate named in the Appendix as the "Rate of interest for delayed payment" from the date upon which sum ought to have been paid by the Employer until the payment subject to production of all required information/ clarifications by the contractor.
34. **Matters to be finally determined by Bank:** The decision, opinion, direction Certificate (except for payment) with respect to all or any of the matters under Clause 2, 4, 7, 8, 13, 17, 18, 19, 20, 21, 22, 28 (a, b, c, d, e, f) hereof (which matters are herein referred to as the expected matters) shall be final and conclusive and binding on the parties hereto and shall be without appeal. Any other decision, opinion, direction, shall be subject to the right of Arbitration and review under the Clause 35 hereof in the same way in all respects (including the provisions as to opening the reference) as if it were a decision of the Bank's Engineer.
35. **Settlement of disputes by Arbitration:** All disputes and differences of any kind whatever arising out of or in connection with the contract or the carrying out of the works (whether during the progress of the works or after their completion and whether before or after the determination abandonment or breach of the contract) shall be referred to and settled by the Bank who shall state its decision in writing. Such decision may be in the form of a final certificate or otherwise. The decision of the Bank with respect to any of the excepted matters shall be final and without appeal as stated in preceding clauses. But if either, the Contractor be dissatisfied on any matter the Contractor may within 28 days after receiving notice of such decision give a written notice to the other party requiring that the matters in dispute be arbitrated upon. Such written notice shall specify the matters, which are in dispute or difference of which such written notice has been given. If both the parties agree a single arbitrator would be appointed for the purpose. In case no agreement could be reached on the appointment of single arbitrator, both the parties will nominate one person each as an arbitrator on their behalf. The two arbitrators nominated by the parties shall nominate one more person to act as third arbitrator or umpire.

The arbitrator or arbitrators, as the case may be, shall have power to open up, review and revise any certificate, opinion, decision, requisition or notice, save in regard to the excepted matters, referred to in the preceding clause, and to determine all matters to dispute which shall be submitted to arbitration and of which notice shall have been given as aforesaid.

The arbitrator or arbitrators, as the case may be, shall make his or their award within one year (or such further extended time as may be decided by him or them as the case may be with the consent of the parties) from the date of entering on the reference. In case during the arbitration proceedings the parties mutually settle or compromise their dispute or difference, on the parties filing their joint memorandum of the settlement or compromise, the arbitrator or the arbitrators as the case may be, shall make an award in terms of such settlement or compromise.

Upon any such reference, the decision on the cost incidental to the reference and award respectively shall be in the discretion of the arbitrator or arbitrators as the case may be, who may determine the amount thereof or direct the same to be taxed as between the party and party, and shall direct by whom and to whom and in what manner the same shall be borne and paid.

This submission shall be deemed to be a submission to arbitration within the meaning of the Indian Arbitration and Conciliation Act, 1996 or any statutory modification thereof. The award of the arbitrator or arbitrators, as the case may be, shall be final and binding on the parties. It is agreed that the Contractor shall not delay the carrying out of the works by reason of any such matter, question or dispute being referred to arbitration, but shall proceed with the works with all due diligence and shall until the decision of the arbitrator or arbitrators is given, abide by the decision of the Bank. No award of the arbitrator or arbitrators, as the case may be, shall relieve the Contractor of his obligations to adhere strictly to the Bank's instructions with regard to the actual carrying out of the works. The Employer and the Contractor hereby also agree that arbitration under this clause shall be a condition precedent to any right of action under the contract.

36. **Right of technical scrutiny of final bill:** The Employer shall have a right to cause a technical examination of the works by any of the persons or organization as appointed by the employer and the final bill of the Contractor including all supporting vouchers, abstracts, etc. If as a result of this examinations or otherwise any sum is found to have been overpaid or over certified it shall be lawful for the Employer to recover the sum from any payment due to the Contractor for this works or any other works being carried out by the contractors elsewhere under the RESERVE BANK OF INDIA.
37. **Employer entitled to cover compensation paid to workmen:** If, for any reason, the Employer is obliged, by virtue of the provisions of the Workmen's Compensation Act, 1923, or any statutory modification or re-enactment thereof to pay compensation to a workman employed by the Contractor in execution of the works, the Employer shall be entitled to recover from the Contractor the amount of compensation so paid, and without prejudice to the rights of the Employer under the said Act. The Employer shall be at liberty to recover such amount or any part thereof by deducting it from the security deposit or from any sum due by the Employer shall not be bound to contest any claim made against it under the said Act, except on the written request of the Contractor and upon his giving to the Employer full security to the satisfaction of the Employer for all costs for which the Employer might become liable in consequence of contesting such claim.
38. **Abandonment of works:** If at any time after the acceptance of the tender, the Employer shall for any reasons whatsoever not requires the whole or any part of the works to be carried out, the Bank shall give notice in writing to the Contractor who shall have no claim to any payment of compensation or other-wise whatsoever on account of any profit or advantage which he might have derived from the execution of the whole works.

39. Return of surplus materials: Notwithstanding anything to the contrary contained in any or all the clauses of this Contract, where any material for the execution of the Contract is procured with the assistance of the Employer by purchase made under orders or permits or licenses issued by Government, the Contractor shall hold the said materials economically and solely for the purpose of the Contract and not dispose of them without the prior written permission of the Employer and return it to the Employer, if required by the Employer, at the price to be determined by the Bank having due regard to the conditions of the materials, the price to be determined not be exceed the purchase price thereof inclusive of GST and other such levies paid by the Contractor in respect thereof, in the event of breach of the aforesaid condition, the Contractor shall in addition to being liable to action for contravention of the terms of licenses or permit and/or criminal breach of trust, be liable to Employer for all moneys, advantages or profits resulting or which in the usual course would have resulted to his by reason of such breach.

40. Non-Disclosure Clause: The Contractor shall not disclose directly or indirectly any information, materials and details of the Bank's infrastructure / systems / equipment etc, which may come to the possession or knowledge of the Contractor during the course of discharging its contractual obligations in connection with this agreement, to any third party and shall at all times hold the same in strictest confidence. The Contractor shall treat the details of the contract as private and confidential, except to the extent necessary to carry out the obligations under it or to comply with applicable laws. The Contractor shall not publish, permit to be published, or disclose any particulars of the works in any trade or technical paper or elsewhere without the previous written consent of the Employer. The Contractor shall indemnify the Employer for any loss suffered by the Employer as a result of disclosure of any confidential information. Failure to observe the above shall be treated as breach of contract on the part of the Contractor and the Employer shall be entitled to claim damages and pursue legal remedies.

The Contractor shall take all appropriate actions with respect to its employees to ensure that the obligations of non-disclosure of confidential information under this Agreement is fully satisfied.

The Contractor's obligations with respect to non-disclosure and confidentiality will survive the expiry or termination of this agreement for whatever reason.

41. Right of employer to terminate contract in the event of death of Contractor if individual: Without prejudice to any of the rights or remedies under this Contract, if the Contractor, being an individual, dies, the Employer shall have the option of terminating the contract without incurring any liability for such termination.

(i) The contractor shall abide by and fulfill all requirements laid down under the Contract Labour (Regulation and Abolition) Act, 1970 and the rules framed there under.

(ii) The contractor should ensure payment of minimum wages to all labourers/workmen staff employed by him. Contractor should submit a certificate to the effect that, he has actually paid all the dues of all the labourers of all descriptions engaged by him for completion of the awarded job/work/project at the rate which is not less than the one prescribed under Minimum wages Act, 1948 and he has complied with the provisions of CLRA Act with regard to providing the essential amenities to the contract labourers. Further, he may facilitate Bank's representative to verify and certify the veracity of such certificate.

42. Sexual Harassment of women at workplace

1. a) The contractor / agency shall be solely responsible for full compliance with the provisions of "the Sexual Harassment of women at work place (Prevention, Prohibition and Redressal) Act, 2013". In case of any complaint of sexual harassment against its employee within the premises of the Bank, the complaint will be filed before the Internal Complaints

Committee constituted by the Contractor / Agency and the Contractor / Agency shall ensure appropriate action under the said Act in respect of the complaint.

b) Any complaint of sexual harassment from any aggrieved employee of the contractor against any employee of the Bank shall be taken cognizance of by the Regional Complaint Committee constituted by the Bank.

c) The contractor shall be responsible for any monetary relief that may need to be paid in case the incident involves the employees of the contractor, for instance any monetary relief to the Bank's employee, if sexual violence by the employee of the contractor is proved.

d) The contractor shall be responsible for educating its employees about prevention of sexual harassment at work place and related issues.

e) The contractor shall provide a complete and updated list of its employees who are deployed within the Bank's premises.

I / We hereby declare that I / we have read and understood the above instructions for guidance of tenderers and accept the same.

Date :

Place :

Signature of Authorized signatory with seal.

Name and Address:

SPECIAL CONDITIONS

1. The tenderer may please note that the work in question shall be carried out in the normal working hours inside the Bank's residential premise with least disturbance to the residents by advance planning, proper sequence of work in consultation with the Bank's Engineers. The work will have to be completed within the stipulated time frame and no extra charges will be paid under any circumstances for the late working hours.
2. The entire materials for the work shall be brought to the working area through the staircase only.
3. All the materials shall be first/premium quality confirming to IS standards.
4. The tenderer shall use only approved materials as specifically stated in the Schedule of Quantities/Approved list of materials. The Bank will be at liberty to choose any brand of materials from the approved brand names in the list. Samples of any materials used in any of the works should be got approved by Bank's Engineer or his representative before proceeding with bulk purchase.
5. Wherever contractor proposes to use equivalent make (i.e. other than specified) the same shall be done after prior approval of Bank's Engineer, Any additional expenditure and time due to this shall be solely on contractor account and no claims what so ever shall be entertained in this regard.
6. Materials brought to the site shall be intimated to the Bank's Engineer immediately for inspection of quality and measurement of quantity of the materials
7. The contractor shall submit a properly planned & prepared work programme to the Bank before commencement of the work so as to enable the Bank to intimate other agencies in advance for smooth working, progress and coordination and the time schedule in the work programme should be strictly adhered to.
8. Nine weeks of period of completion mentioned in the tender is inclusive of monsoon period and holidays including Sundays / Saturdays falling within in the contract period. The contractors shall comply with statutory requirements to work on holidays at their own risk & cost and indemnify the Banks for any risks associated with it.
9. The debris/dust or any wastage generated out of the above work shall be cleaned as frequently as required and as instructed by the Bank's Engineer and make the entire premises clear/clean on a day-to-day basis including staircase, passages affected/used by the labourers in the above renovations to the satisfaction of the Bank's Engineers at no extra cost. The entire debris/waste material shall be taken out of the Bank's premises and should not be dumped anywhere in and around the Bank's premises. The contractors are solely responsible if any debris is noticed by the local Corporation and penalty levied.
10. No labourers shall be permitted to stay inside the campus after working hours.
11. The Contractor should have valid Labour License from Labour commissioner wherever the number of labourers engaged is 20 or more.
12. GST shall be included in the rates quoted by the contractor. The rate quoted shall include all such taxes and levies. However, while submitting the bill/ invoice for the work the contractor shall clearly indicate the various components of GST involved in the work value.
13. The Contractor shall have the addresses and photographs of their workmen being engaged by them for the said work. The entry of workmen will be allowed inside the building only on producing the photo pass issued by the Bank & also have to subject themselves to the security restrictions imposed by the Bank.
14. Before quoting the rates, Contractor should inspect the site and understand themselves about the nature and scope of the work.
15. Any damage caused to any of Bank's property shall be made good by the Contractor at their own cost.
16. The Contractor shall carry out the work strictly in accordance with specification details and instructions of the Bank's Engineer.
17. The Contractor shall make their own arrangements for storing of their materials at site.

18. Rate quoted should include for all necessary testing of materials as required and directed by Banks Engineers.
19. Contractor should post a qualified Site Engineer for day-to-day supervision of work.
20. The successful tender shall also be responsible for safety & security of their materials & also for ensuring fire prevention steps at all the times in working premises including their part of work.

I / We hereby declare that I / we have read and understood the above instructions for guidance of tenderers and accept the same.

Date :

Signature of Authorized signatory with seal.

Place :

Name and Address:

SAFETY CODE

1. First aid appliances including adequate supply of sterilized dressing and cotton wool shall be kept in a readily accessible place.
2. An injured person shall be taken to a public hospital without loss of time, in cases where the injury necessitates hospitalization.
3. Suitable and strong scaffolds should be provided for workmen for all works that cannot safely be done from the ground/floor.
4. No portable single ladder shall be over 8 meters in length. The width between the side rails shall not be less than 30 cm. (Clear) and the distance between two adjacent rungs shall not be more than 30 cm. When a ladder is used an extra mazdoor shall be engaged for holding ladder.
5. Every opening in the floor of a building or in a working platform shall be provided with suitable means to prevent the fall of persons or materials by providing suitable fencing or railing whose minimum height shall be one meter.
6. No floor, roof or other part of the structure shall be so overloaded with debris or materials as to render it unsafe.
7. Workers employed on mixing and handling material such as cement mortar or concrete and lime mortar shall be provided with protective footwear and rubber hand-gloves.
8. (i) No paint containing lead or lead products shall be used except in the form of paste or readymade paint.

(ii) Suitable facemasks should be supplied, for use by the workers when the paint is applied in the form of spray or surface having lead paint dry rubbed and scrapped.
9. Overalls shall be supplied by the Contractor to the painters and adequate facilities shall be provided to enable the working painters to wash during the periods of cessation of work.
10. Hoisting machines and tackle used in the works, including their attachments, anchorage and supports shall be in perfect condition.
11. The ropes used in hoisting or lowering material or as a means of suspension shall be of durable quality and adequate strength and free from defects.

FIRE SAFETY CODE

1. Cutting / drilling machine and other electrically operated equipments used at site shall be plugged into correctly rated electrical outlets.
2. Only ISI marked 3-pin plug and other appliances and equipments shall be used.
3. Electrical power cables/wires used shall not have any joints and shall be properly rated.
4. All electrical appliances i.e. drilling, cutting machine etc. shall be safely and securely earthed to prevent leakage current while in operation.
5. Two buckets of water and sand shall be kept in an easily accessible area on the site.
6. Fire extinguishers recommended shall be kept on the site.
7. Used paint drums shall be stored in specified store only after closing them properly.
8. Personal protective equipments such as safety shoes, hand gloves, welder's mask, ear plug etc. depending upon the requirement of the work shall be provided by the contractor to the workmen to prevent occupational health hazards.
9. The safety belt shall be provided by the contractor and used by the workmen while working from height for more than 10 feet from Ground level.
10. None of the passages near lift lobby and staircases shall be used for stacking / dumping any kind of materials/waste.
11. None of the fire extinguishers shall be removed/shifted from its designated location.
12. Power supply shall be switched off from the mains when equipment is not in use.
13. Wood-shavings and sawdust generated from the work shall be collected on daily basis, removed from site and stored at the designated place in proper manner.
14. Any debris generated from the work shall be collected on daily basis, removed from site and stored at the designated place in proper manner.
15. Battery operated emergency light/torches shall be provided by the contractor to the workmen while working beyond office hours.

Place:
Date:

Signature of the Tenderer:
Name and Address:

APPENDIX HEREIN BEFORE REFERRED

1	Defect liability Period (DLP)	12 months from the date of issue of virtual completion certificate.
2	Period of final measurement	1 month from the date of Virtual completion.
3	Earnest Money Deposit (EMD)	2% of accepted contract value from successful bidder.
4	Performance Bank Guarantee (PBG)	5% of the contract value.
5	Release of EMD & PBG	On successful completion of work.
6	Date of commencement	10 th day from the issue of work order.
7	Date of completion	Nine weeks from the tenth day of the issue of work order
8	Rate of Liquidated Damages (LD)	0.25% of the contract value per week of delay subject to a maximum of 10% of the total accepted contract value.
9	Value of work for Interim Certificate	Only 1 st and final bill.
10	Retention Percentage (RMD)	5%
11	Release of RMD	On completion of Defect Liability Period.
12	Period of honoring interim certificate	15 Days (subject to production of correct bill in all aspects)
13	Period of honoring final certificate	30 Days (subject to production of correct bill in all aspects)
14	Interest for delayed payment	Three percent per annum.

I / We hereby declare that I / we have read and understood the above instructions for guidance of tenderers and accept the same.

Date :
Place :

Signature of Authorized signatory with seal.
Name and Address:

List of approved makes / manufacturers of materials.

1.	Cement	A.C.C, Malabar, Coramandal, Ramco, Sankar, Ambuja or approved equivalent.
2.	White Cement	Birla White, J.K. White or approved equivalent
3.	Waterproof chemicals	Dr. Fixit, Fosroc, BASF or approved equivalent
4.	CPVC/ PVC pipes and fittings	Supreme, Finolex, Ashirwad, Prince or approved equivalent
5.	SS sink	Nirali, Diamond, Prince or approved equivalent
6.	Vitrified Tiles/ Ceramic tiles	Johnson, kajaria, RAK, Somany, Nitco, BELL, simpolo or approved equivalent
7.	Tile grouts / jointing compounds	Bal Endura silver star plus, MYK Latecrete 315 or approved equivalent
8.	Gypsum false ceiling	M/s Gyproc India Ltd – gyp steel ultra-sections
9.	Marine plywood (BWP Grade)	Green Ply, Anchor, Kitply, Century
10.	Aluminium sections	Jindal, Hindalco or approved equivalent
11.	Laminate	Merino, Greenlam, Royal touche
12.	Sanitary fittings	Parryware, Hindware, CERA, Toto or approved equivalent
13.	C.P fittings	Jaquar, Hindware or approved equivalent
14.	Glass	Sain Gobain, Modi or approved equivalent
15.	SS fittings	Hettich or approved equivalent
16.	SS Accessories & slides	Ebco, Sleek or approved equivalent
17.	Paints	Asian, ICI Dulux, MRF, Berger, Shalimar, Nerolac,
18.	Putty	Birla White, JK, Goldsize Putty by Shalimar Paints Ltd or approved equivalent.

- a) The Contractor shall produce samples of 2-3 makes as the case may be for Bank's approval before using the same in the works.
- b) Materials approved by the Bank shall only be used in the work including approval of PC rates for Basic rate items.

Date:

Signature of the Tenderer with seal:

Place:

UN PRICED SCHEDULE OF QUANTITIES

Item No.	Description of Item	Quantity	Unit
1	<p>Carefully dismantling/ disengaging and removing the following items from interior area of flat (approx. carpet area of flat is 1100 Sqft).</p> <p>a) Existing marble mosaic / ceramic tile, Kota or any other flooring / skirting / wall dado including bed / back mortar, wall plastering etc., by approved methods, so as to expose the R.C.C floor slab / brick wall without damaging the slab / wall. Approximate area of dismantling is 180 Sqm.</p> <p>b) Carefully disconnecting and removing all the existing internal-exposed/concealed plumbing and sanitary lines including wall pieces, all fittings and fixtures like taps, stop cocks, shower, wash basin, medicine chest, mirror, traps etc in all the toilets in the flat.</p> <p>c) Dismantling existing RCC cooking and working platforms with finishes in kitchen area including supporting pillars, cabinets with shutters, raised platform, wooden shelves, sink, RCC loft slab of size 2430mm x 930mm x 100mm etc</p> <p>d) Existing Indian/European type water closets including 'P'/ 'S' traps and pipes buried below floor, the existing floor/ nahani traps and connected pipelines below floor, the existing sunk fill of cement concrete/ brick jelly concrete (about 250 to 450 MM depth) in all the toilets/ bathroom and kitchen morie area by approved methods so as to expose the bottom slab and side walls to receive new water proof treatment etc.</p> <p>e) Carefully removing the fibre mosquito netlons on windows & ventilators along with the velcro / staples on the frames of windows / ventilators, curtain rods with brackets etc.</p>		
	<p>f) Wooden doors with frames (4 Nos), wooden ventilators (4 Nos) in toilet/ bathrooms, wooden window (1 No) in kitchen area of the flat.</p> <p>g) Carefully dismantling the existing wooden wardrobes in the bedroom area of flat (2 Nos).</p> <p>h) 115mm thick brick wall with both side finishes in bath/ toilet area of flat as per the sketch to remodel the existing layout. Approx. area of wall to be dismantled is 10 Sqm.</p> <p>Rate shall be inclusive of thoroughly cleaning the surface using water, wire brush or any other approved methods, stacking the usable items and disposing off and carting away the debris out of the Bank's premises etc all complete as directed by Bank's Engineer.</p> <p>Note: For this item, the rate to be quoted for the entire scope of works mentioned above shall be as lumpsum for the flat.</p>	1.00	Job
2	<p>Brick work</p>		
	<p>Providing and constructing 115 mm thick brick masonry for walls, closing the openings etc. wherever required, using best quality locally available bricks in CM 1:6, in correct plumb, line and level, providing proper key to the adjoining wall/ column/ flooring etc., placing 2 nos 6mm dia re bars in concrete encasement at every 4th course, raking the joints, necessary scaffolding, curing, cleaning, removal of debris if any outside the Bank's premises etc. all complete as directed by the Bank's Engineer.</p>	12.00	Sqm
3	<p>Cement plaster with smooth finish</p>		

	Providing and rendering cement plaster of average thickness of 20 mm or above for new walls including plastering in patches, in C.M. 1:4 (01 port land cement: 04 M. sand) true to plumb and line over the existing / new walls to match with the adjoining plastering and finishing the same smoothly and neatly etc. The rates shall include necessary curing scaffolding, all leads and lifts, removal of debris etc., all complete as directed by the Bank's Engineer	10.00	Sqm
4	Cement plaster with rough finish		
	Preparing the surface of the masonry / RCC walls by raking, watering and thorough cleaning using wire brush, broom, providing and applying average 20 to 25 mm thick cement plaster using CM 1:4 (comprising of a first coat of 12 mm thickness, and a second coat of 9 to 12mm thickness) using approved quality OPC and M. sand, true to plumb, level and line. The wall plaster shall have an even surface and shall be finished with recessed joints to receive the tile dado. The rate shall include for cutting, curing, labour, all leads and lifts, etc. required for the finished work, all as directed by the Bank's Engineer.	64.00	Sqm
5	Water proofing to sunken area in washrooms and morie area of flat by engaging approved water proofing specialized firm as per their specifications but approved by the Bank which comprises thorough cleaning of the surfaces, applying water proof chemical coating and above which plastering with CM 1:3, 15 to 20 mm thick mixed with approved make polymer to the entire floor slab of sunken portion including on all the four sides up to 150mm above proposed floor level and testing for leakage by ponding of water etc. complete. The rate shall include for filling back of the sunken portion with the old surkhi/brick bat coba, providing additional surkhi / brick bat coba wherever necessary, providing and laying flooring on top of approx. 50 to 75mm thick with CC 1:2:4 using 20mm downgraded aggregates mixed with water proofing compound of approved make etc., all complete as directed by the Bank's Engineer. Approximate plan dimensions of washrooms to be treated is 1250mm x 1880mm - 2 Nos, 1150mm x 1880mm - 2nos and kitchen morie is 850 x 750mm.	1.00	Job
6	Supplying and laying concealed plumbing lines: - Providing, cutting, fixing, testing and commissioning concealed waterlines of 20mm diameter using C-PVC threaded pipe of SDR 11 including all the necessary specials like elbows, tees, couplings etc. All the concealed lines shall be properly fastened to the wall using GI clamps @maximum spacing of 450mm. Rate shall be inclusive of making necessary cutting and chasing on the walls to receive the plumbing lines, placing the plumbing line, properly packing using cement mortar admixed with waterproofing chemicals, pressure testing for leakage etc. Actual linear measurement shall be reckoned for payment purpose.	32.00	Rmtr
7	Providing and fixing PVC pipes of 50 mm diameters (minimum test/working pressure 6 kg/sq.cm) of approved quality and make, including all fittings, of the same manufacturer of the pipes or approved equivalent for the waste lines for toilet, bathroom, wash basin, washing machine and kitchen sink and fixing the pipes with clamps at 1 mtr spacing for concealed/external work including cutting chases in the wall/ floor for concealing the pipes, connecting to duct line/manhole, including fixing pipes with concrete blocks etc. complete. The rate shall inclusive of cutting, jointing of pipes with fittings and to the existing PVC	8.00	Rmtr

	pipes in the duct with solvent cement of approved quality, and making good the damages by necessary plastering, including testing of joints/ pipelines, etc. for leakage etc. all complete as directed by the Bank's Engineer.		
8	All same as item 7 above, but for PVC pipes of 75mm dia	8.00	Rmtr
9	All same as item 7 above, but for PVC pipes of 110mm dia	5.00	Rmtr
10	Nahani Trap: - Providing, fixing and connecting approved quality and make PVC Nahani trap/ multi trap of 100x75mm dia outlet with a minimum water seal of 50mm to the wastewater pipeline. Rate shall be inclusive of making trenches of minimum width 250mm and filling the sump using concrete 1:1.5:3 admixed with waterproofing chemical, providing and fixing 125mm dia SS gratings etc. all as directed by the Bank's Engineer.	6.00	No.
11	Providing and laying screed concrete: Preparing the surface of the R.C.C floor slab by thorough cleaning and priming with cement slurry admixed with approved make and quality water proofing compounds, providing, mixing, laying, spreading, levelling and manually consolidating using hand rammers P.C.C 1:3:6 for an average thickness 40 to 50 mm using approved quality 12 mm and down size graded broken granite stone aggregates, approved quality M. sand and Portland cement of approved make, as screed layer in flooring. The surface of the screed laid as above shall be made rough using wire brushes or brooms. The work shall include necessary curing, disposing off and carting away the debris from the Bank's premises etc all complete as directed by the Bank's Engineer.	6.00	Cum
12	Vitrified tile flooring: Preparing the surface of the screed concrete layer / floor slab by thorough cleaning and priming with cement slurry to receive the new flooring, providing and laying flooring in the approved pattern, line, level etc., using 800 mm x 800 mm or approved size polished vitrified tiles (anti-skid tiles in balcony area) of approved make and shade over a bed of cement mortar prepared by hand mixing approved make Portland cement and approved quality M-sand in the ratio 1: 4, laid, spread and consolidated to get an average consolidated thickness of 20 mm. The tiles shall be set with a floating layer of grey cement slurry and using 3mm spacers, the joints shall be pointed with epoxy grouts of approved make and quality to match with the shade of the tiles. The rate shall include curing, cleaning of the finished work, all leads & lifts etc required for the finished work all as directed by the Bank's Engineer. (Basic rate of tiles to be considered- Rs. 650/- per Sqm excluding GST. No carriage/ transportation will be considered for the basic rate adjustment). Only exposed finished area of work shall be measured and paid for	105.00	Sqm
13	Vitrified tile Skirting: Preparing the surface of the walls to receive the new skirting by watering and cleaning, providing and fixing 150 mm height skirting cut out of 800 x 800 mm or approved size fully vitrified tiles of approved make and shade over a backing of CM 1: 4 (using approved quality M-sand and OPC) for the required thickness, true to plumb and line(only tile thickness shall be projected from the surface of wall) , set with grey		

	<p>cement paste and joint pointed with epoxy grouts of approved make and quality to match with the shade of the tile tile grouts of approved make and quality to match with the shade of the tile. The rate shall include machine grinding and buffing of the exposed edges / sharp corners, machine cutting, curing, cleaning of the finished work, all leads & lifts, etc required for the finished work all as directed by the Bank's Engineer. The rate shall also include repairs to the plaster damaged during dismantling (including new area to be made up due to difference in height of existing skirting and new skirting) and finishing of the skirting and making to match with the adjacent surfaces. (Basic price of tiles - Rs. 650/- per Sqm excluding taxes. No carriage/ transportation will be considered for the basic price adjustment).</p>	14.00	Sqm
14	<p>Wall Dado tile work: - Providing and fixing 1st quality/ premium quality vitrified/ ceramic glazed tiles of size 600mm x 600mm (or approved nearest available size) and of approved shade and make, for wall dado over the plastered and bordered surface as per item No: 04 with 6 mm average thick back mortar of CM 1:3 (1 cement : 3 M. sand) and set with cement paste spread fully over the whole back area of the tile (the work is liable to be summarily rejected if the joint is found susceptible to hollowness) and 3mm spacers for horizontal joints of tiles. The tile joints shall be pointed with epoxy grout of matching shade, curing, etc. all complete as directed by the Bank's Engineer. The rate shall include for all cutting, grinding the exposed edges, pvc beading on exterior corners, wastage, proper finishing, using different shades of tiles if any in the dado etc. Basic rate of tiles to be considered is Rs 600/-per Sqmtr. exclusive of GST. No carriage / transportation will be considered for the basic price adjustment. Only exposed finished area of work shall be measured and paid for</p>	64.00	Sqm
15	<p>Anti-skid flooring in washrooms: - Providing and laying first quality / premium quality anti-skid vitrified/ ceramic floor tiles of size 600mm x 600mm (or approved nearest available size), of approved shade and make, in floor laid over 20 mm thick bed of cement mortar 1:4 (1 cement : 4 M. sand), and cement paste spread fully over the base area of the tile including providing proper slope for draining out the water fully and smoothly without any traces of water stagnating anywhere (the work is liable to be summarily rejected if the slope is not provided properly or the joint is found susceptible to hollowness). The tiles shall be laid using 3mm spacers and rendering the joints with epoxy grout to match the shade of the tile, curing, etc. all complete as directed. The rate shall include for all cutting, wastage, proper finishing etc. Basic rate of tiles to be considered is Rs 650/- per Sqmtr. exclusive of GST. No carriage / transportation will be considered for the basic price adjustment. Only exposed finished area of work shall be measured and paid for</p>	7.00	Sqm
16	<p>Granite sill/ soffit/ jambs for doors and windows: Carefully dismantling the existing plastering on the surface, providing and fixing 16 to 18mm thick mirror polished granite slabs (70 to 200mm wide) for sills/ soffit/ jambs of doors, windows, ventilators etc in single piece in true level, line etc fixed with 20mm thick base cement mortar 1:4 in full width of wall. Rates shall include for preparation of surface, moulding the exposed edges of granite to required profile and polishing</p>		

	the same to mirror finish etc. all complete as directed by the Bank's Engineer. Basic rate of granite to be considered is Rs 275/- sqft excluding GST.	13.00	Sqm
17	Aluminium doors for washrooms: - Providing, fabricating and fixing panelled aluminium door shutters with door frame of approx. overall size 750 x 2050mm on the granite finished jambs of door openings in washrooms using powder coated aluminium sections of approved make and shade and the panels with 4mm thick ACP sheets etc. The sections for door frame shall be of 63x 46.5x 1.35mm and shutter frame are of 40 x 38.10 x 1.20 mm for the styles, middle and top rail, and the bottom rail of the shutter with section size 100 x 38.1 x 1.20 mm etc. All sections are of approved make and powder coated with approved colour / shade to a minimum thickness of 50 microns etc. The rate shall inclusive of using best quality neoprene/ EPDM rubber gasket, GI. Clips, fixing of handles, SS hinges, tower bolts, etc. all complete, as directed by the Bank's Engineer.	3.00	Nos
18	Aluminium ventilators for washrooms: Providing and fixing new ventilator of approx. size 600 mm x 850 mm made with powder coated aluminium frames of suitable sections and louver panels using 5 mm thick frosted glass fixed to the frame using cleats and beading and having a 8" square opening for fixing exhaust fan including providing additional frame work if necessary etc. all complete as directed by the Bank's Engineer. All the corners and joints of the frame & sash shall be mitred cut & jointed well and the frame joints with wall/ ceiling etc. shall be properly sealed with silicon sealant etc.	4.00	No
19	Aluminium sliding window for kitchen: Supplying and fixing of powder coated aluminium windows of approved make with frames having 2 tracks for 2 glass shutters and one for mesh shutter. The bottom frame is of 61.85 x 31.75 x 1.50mm with minimum weight of 0.909kg/ mtr, sides and top with sections having minimum weight of 0.784kg/mtr etc. The sliding shutter sections shall be of 40x18x1.55mm with minimum weight of 0.547kg/mtr etc. Fly mesh shutter shall be made with suitable powder coated sections with SS net. Sliding shutters are provided with 5mm thick plain glass fitted to the frame with EPDM gaskets etc. The top 300mm high portion of the window shall be made fixed panel and an opening for fixing exhaust fan by giving additional horizontal/ vertical frames having sections of matching size etc. All the corners and joints of the frame & sash shall be properly jointed.		
	System shall have adequate drainage mechanism to permit the escape of water from horizontal member beneath each sealed unit. Windows has to be provided with locking arrangements, nylon rollers etc as per the requirement, as directed by Bank's Engineer. The complete window shall be fixed into the prefinished opened places, by drilling & fixing through the outer frame using high quality fasteners & silicon sealant is applied to fill up the gap between wall & window frame for leak-proof installation, and completion. The opening shall also be provided with MS safety grills in required design using 12mm square MS rods properly welded and inserted to the walls making necessary cut outs, concreting etc. and finishing, the grill shall be painted with two coat of synthetic enamel paint of approved make and shade over a coat of zinc chromate primer etc. all complete as directed. Approx. overall size of window shall be 1000mm x 860mm.	1.00	No

20	Gypsum Board false ceiling		
	Providing and fixing suspended, stepped type gypsum board plain false ceiling system and coving in different levels as per the specifications of M/s Gyproc India Ltd firmly fixed on Gypserra framework sections all as per the attached sketch and as detailed below:		
	i) Perimeter channels of 20mm X 28mm x30mm all along the wall fixed with the help of nylon sleeves and screws @ 600mm c/c. ii) Intermediate channel 15mm x45mm x 15mm at a spacing of not more than 1200 mm c/c.		
	iii) Ceiling angle 25mmx10mmx 0.55 mm thick fixed to soffit with GI cleat and steel expansion anchor fasteners. iv) Ceiling channel 80mmx 26mmx 51 x 0.5mm @450mm/ 475mmc/c. shall be fixed in a direction perpendicular to G.I intermediate channel with connecting clips made out of 2.64mm dia x 230mm long G.I wire at every junction. v) 12.5 mm thick Plain Gypsum board is fixed to the ceiling section with 25mm drywall screws @ 230mm c/c. Finally boards are to jointed and finished so as to have flush look and levelling the board so as to be in one single plane which includes filling and finishing the board edges with jointing compound, paper tape etc complete.		
	vi) Painting the false ceiling surfaces with two or more coats of first quality 100% acrylic interior emulsion paint of approved make and shade over a coat of primer after adequate surface preparation, putty work etc., complete.		
	Rate shall include cut out/openings for fixing light fittings with necessary additional framework, wastages, finishing all etc. complete. No deduction in area measurement will be made for openings not exceeding 0.4 sq.m. and no extra measurement will be made for forming such opening. Net exposed finished area shall be measured and paid for. The works shall be carried out as per the manufacturer's specifications using cold rolled Gypsteel gypserra sections and Gypsum boards manufactured by Gyproc India Ltd all etc., complete as directed by the Bank's Engineer.		
	Note: -The false ceiling shall be provided in true line, level, profile etc as per the detailed sketch and specifications and finished in a high-class manner. Required no. of trap doors shall be provided in ceiling.	15.00	Sqm
21	Providing and fixing stepped POP cornice of approx. 100mm size of approved design/ pattern with adhesive/ POP, at junctions/ joints of wall and ceiling in perfect lines and levels, etc. including applying primer, putty and two coats of interior emulsion paint, finish neatly etc. all complete as directed by the Bank's Engineer.	40.00	Rmtr
22	Wall hung wash Basin: - Providing and fixing wash basin of 500x400mm size with half pedestal of approved make white in colour with CP waste coupling, 32 mm dia flexible waste pipe, 15mm dia pvc connection etc. complete. The wash basin shall be mounted/ fixed to the wall using approved quality fisher bolts/ heavy duty aluminium clamps, inlet/ outlet connections etc. Rate quoted shall be inclusive of sealing the gaps between the wash basin/pedestal and the adjoining surface using approved quality polysulphide sealant etc., all complete as directed by the Bank's Engineer. Basic rate of wash basin with pedestal to be considered is Rs 3500/- excluding GST.	3.00	Nos

23	<p>Providing and making wash basin counter of approx. overall plan size 1200 mm x 600 mm as per the sketch enclosed and with the following specifications.</p> <p>a) Constructing necessary support pillar (1 No), in brick masonry using best quality locally available bricks in CM 1:4 and finishing the same with cement plaster using CM 1: 4.</p> <p>b) Providing and making counter with 50 mm thick RCC slab (1: 1½ :3) with required reinforcements and finished top & front fascia with 16 to 18mm thick granite slab (Basic rate Rs 275/ Sqft excluding GST) with necessary edge moulding, leaving opening for countertop wash basin, cutting grooves on the wall for proper all round supports etc.</p> <p>c) Providing and fixing vitreous countertop wash basin, white/ snow white in colour, of approved quality and make (Basic rate – Rs 5000/- excluding GST) fixed over the granite top in approved methods, including all fittings like CP pillar cock (Basic rate – Rs 2500/- excluding GST), 15 mm pvc connection, 32 mm dia flexible pvc waste pipe, cp waste coupling, etc.</p>		
	<p>d) Providing and fixing cabinet with shutters for open area below the counter (up to 25 cm above floor level) made with 18mm thick BWP grade marine plywood pasted with 0.80mm thick laminate inside surfaces and 1mm laminate on exterior surfaces including fixing necessary edge bands etc. The shutters (2 Nos) shall be fixed to the cabinet with 2 nos SS auto close hinges 2 nos per shutter, necessary SS handles, magnets etc all complete as directed by the Bank's Engineer.</p>	1.00	No
24	<p>Providing and fixing wall mounted water closet inside the master toilet, using elongated Wall hung closet bowl with cistern and seat cover, all of approved brand including cost of all accessories, connecting the same to the vertical stack with PVC pipe of suitable diameter charges for installation, transportation charges etc all complete as directed by the Bank's Engineer. Basic rate to be considered for EWC set (EWC+ Flush tank+ seat cover) is Rs 10.000 excluding GST.</p>	1.00	No
25	<p>Providing and fixing white, floor mounted EWC with seat cover and necessary P/S trap and connecting the same to the vertical stack with necessary PVC pipe of suitable diameter of approved quality, all as per the directions of the Banks Engineer. The P/S trap shall be set in waterproof cement concrete and joints shall be made watertight and tested for the same. The rate shall also include for providing and fixing 10 litre capacity P.V.C dual flush tank with 15 MM P.V.C connection, 32 MM dia P.V.C flush pipe and all other accessories required and connecting the same to the EWC / water lines etc. as directed by the Banks Engineer. Basic rate to be considered for EWC + seat cover+ Flush tank is Rs 7500/- exclusive of GST</p>	2.00	Nos
26	<p>Providing and fixing the following CP fittings of “Jaquar Continental” make for the flat.</p> <p>a) Angular stop cock with wall flange (Model-059KN) – 12 Nos.</p> <p>b) Wall mixer with provision for overhead shower with 115mm long bend pipe (Model CON - 273KNUPR) – 3 Nos</p> <p>c) Pillar cock (model-011KN)– 3 Nos.</p> <p>d) Two-way Bib cock with wall flange (model -041KN) - 3 Nos.</p> <p>e) Shower arm 190mm long (model - SHA 477) with 100mm dia shower rouse (model OHS 1989) – 3 Nos.</p>		

	<p>f) 20mm dia concealed stop cock (Model – ALD089FT) including exposed part (CON 089KN)– 2 Nos.</p> <p>g) CP health faucet (Hand shower) with 8mm diameter, 1.2-meter-long flexible tube & wall hook with N.R.V (Back flow preventer) model - ALD-573 - 3 Nos</p> <p>h) SS Sink Cock with swinging casted spout (Model CON-347KN) - 1 No.</p> <p>h) Towel rod – 600mm long (Model ACN1111NM)– 3 Nos.</p> <p>j) Towel ring Square (Model ACN 1121N) – 1 No.</p> <p>k) Corner glass shelf (Model ACN 1173) – 1 No.</p> <p>l) Mirror glass shelf – 600mm long (Model ACN 1171N) – 1 No.</p> <p>m) Soap dish (Model ACN 1131N) – 3 Nos.</p>	1.00	Job
27	Supplying and fixing bathroom cabinets of (Medicine Chest) approved design with shelves, brush holders etc. made from minimum 3 MM thick opaque acrylic sheets of approved colour (Basic rate – Rs. 2300 exclusive of GST)	2.00	No
28	Providing and fixing 450 mm x 600 x 6 mm thick mirror of approved quality and make with necessary marine plywood backing, PVC framework etc. all complete as directed by the Bank's Engineer.	3.00	Nos
29	Providing, making and installing new wardrobe in the opening available in bedroom area with approx. overall size 950mm wide x 580 mm deep x 2050 mm high, and shutters for the open area above the wardrobe having size 950mm x 400mm as per the attached sketch and with the following specifications: -		
	<p>a) The sides, top, bottom, racks, shutters and peripheral bands of wardrobe and shutters for open area shall be made with 16 mm thick BWP grade marine plywood and the back of wardrobe shall be made with 9mm thick ply of same quality including necessary edge beadings etc. all as shown in the sketch. b) Providing and making drawers (2 Nos) with same quality plywood with necessary SS sliders, handle, locking arrangements etc. c) The shutters shall fix to the frame with auto closing SS hinges (4 nos each for wardrobe and 2 Nos each for open area shutters). d) The external surfaces of shutters and peripheral bands are pasted with 1 mm thick decorative laminate of approved make and shade and the entire interior surfaces wardrobe/ shutters are pasted with 0.80 mm thick laminate of approved make and all the exposed edges shall be pasted with edge banding of suitable size etc. all with machine pressing. e) Providing and fixing approved quality and make hardware fittings like multipurpose lock for wardrobe shutters as well as for drawers, SS tower bolt 100mm long (2nos), S S brush finish handles of size 150mm (1 No each for shutters and drawers), S S hanger rod, 25mm dia, with heavy quality end brackets, magnetic catchers for open area shutters, etc. Note: Pasting of laminate, edge beading etc on plywood shall be preferably factory pressed to have better finish and durability.</p>	2.00	Nos
30	Providing, making and installing new wardrobe cum dressing table arrangement in bedroom area with approx. overall size 2100mm wide x 580 mm deep x 2100 mm high, and storage cabinet with shutters for the area above the wardrobe unit having size 3000mm x 750mm as per the attached sketch and with the following specifications: -		

	<p>a) The sides, top, bottom, racks, shutters and peripheral bands of wardrobe/ dressing table and cabinet/ shutters for the above shall be made with 16 mm thick BWP grade marine plywood and the back panel of the above shall be made with 12mm thick ply of same quality including necessary edge beadings etc. all as shown in the sketch.</p> <p>b) Providing and making drawers with same quality plywood with necessary SS sliders, handle, locking arrangements etc.</p> <p>c) The shutters shall fix to the frame with auto closing SS hinges (4 nos each for wardrobe and 2 Nos each for cabinet area shutters).</p> <p>d) The external surfaces of shutters and cabinets are pasted with 1 mm thick decorative laminate of approved make and shade and the entire interior surfaces are pasted with 0.80 mm thick laminate of approved make and all the exposed edges shall be pasted with edge banding of suitable size etc. all with machine pressing.</p> <p>e) Providing and fixing approved quality and make hardware fittings like multipurpose lock for wardrobe shutters as well as for drawers, SS tower bolt 100mm long (2nos), S S brush finish handles of size 150mm (1 No. each for shutters and drawers), S S hanger rod, 25mm dia, with heavy quality end brackets, magnetic catchers for open area shutters, etc. The rate shall inclusive of supplying and fixing 450 mm x 900 x 8 mm thick mirror of approved quality and make fixing on the panelling using required nos of approved quality and make S.S / C.P brass studs including machine polishing the edges etc,</p> <p>Note: Pasting of laminate, edge beading etc on plywood shall be preferably factory pressed to have better finish and durability.</p>	2.00	Nos
31	<p>Providing, fabricating and installing wooden cutlery unit at hall area having approx. dimensions 1200mm(L) x 400mm (W) x 2100mm (H) as per the sketch enclosed and with following specifications. The unit shall be made with 16mm thick BWP grade marine plywood of approved make and shade (back panel 12mm thick), pasted with 1mm thick laminate of approved make and shade on exposed surfaces and 0.80 mm thick laminate on interior surfaces etc. The glass panels in the shutter shall be of 6mm thick toughened glass and the glass racks shall be of with 12mm thick toughened glass. The unit shall be provided with SS auto close hinges for shutters, SS slides for drawers, SS matt finish handles, magnets, locking arrangements, necessary edge beadings etc all complete as directed by the Bank's Engineer.</p>	1.00	No
32	<p>TV Unit: Providing, fabricating and making TV unit at hall area having approx. elevation dimensions 1500mm (W) x 2100mm (H) as per the sketch enclosed and with following specifications. The rear side panelling around TV opening, shall be made by erecting framework made with 50x25x1.20mm anodized aluminium sections @ 600mm c/c spacing both ways and finished with 9mm thick BWP grade marine plywood of approved make and pasted with 1mm thick laminate of approved make and shade. The cabinet below TV unit shall be made with 16mm thick BWP grade marine plywood of approved make pasted with 1mm thick laminate of approved make and shade pasted in approved pattern using adhesives, including providing and fixing necessary edge beadings etc. The cabinet shutters shall be fixed to the framework using 2 Nos SS auto close hinges, glass shutters shall be with 5mm thick float glass, supplying and fixing SS handles, SS accessories for glass doors etc all complete as directed by the Bank's Engineer.</p>	1.00	No

33	Providing, fabricating and installing shoe rack of approx. size 1220mm (L) x 400mm(B) x 650mm (H) as per the attached sketch and with following specifications.		
	The cabinet, intermediate vertical support, shutters etc shall be made with 16mm thick BWP grade marine plywood of approved make pasted with 1mm thick laminate of approved make and shade pasted in approved pattern using adhesives, including providing and fixing necessary edge beadings etc. The back panel of the cabinet shall be made with 9mm thick BWP grade marine plywood of approved make and interior surfaces of cabinet shall be pasted with 0.80mm thick laminate. Intermediate racks (3 Nos) and two drawer units shall be made with 12mm thick BWP grade marine plywood of approved make pasted with laminates and drawers are erected on SS slides of approved quality etc. The shutters shall be fixed to the cabinet using 2 Nos SS auto close hinges, supplying and fixing SS handles, providing louver arrangements on shutters, supplying and pasting 16 to 18mm thick granite slab (Basic rate - Rs 275/- excluding GST) with suitable moulding on exposed edges on top of the shoe cabinet etc all complete as directed by the Bank's Engineer.	1.00	No
34	Fabrication, supply and installation of modular kitchen unit as per the attached sketches and with following specifications.		
	OVERHEAD/ BELOW COUNTER STORAGE UNITS/ CABINETS		
	<p>Carcass The framework/ carcass of the cabinets (overhead and below the counter) shall be made with 16 mm thick BWP grade marine plywood conforming to IS 710 on all sides including backing of the overhead storage units, height adjustable ABS plastic legs of approved size and make and additional frameworks wherever required to be provided. The under-counter cabinets shall have 12mm marine plywood backing.</p> <p>Top The top of the under-counter carcass shall have 18mm thick marine ply fixed on top with 16 to 18mm thick Granite slab for the work surface (slab not more than five pieces for the countertop and basic rate of granite slab to be considered is Rs 275/sqft excluding GST). The granite shall have 60 cm clear width, and the back edge should be inserted into 25mm deep groove in the wall. The exposed edges of the granite countertop shall be bull nosed and polished. Necessary puncture/ grooves shall be made in the slab for accommodating the sink and hole to be made for LPG hose.</p>		
	Shutters for the cabinets below counter shall be made with 16 mm thick BWP grade marine plywood of approved make conforming to IS 710. Each shutter shall be fixed to the framework/ carcass using two number of best quality EURO type Slip-in Hinges and provided with approved quality and profile brush finished SS handle (minimum 100mm long) of approved make. The shutter of the overhead cabinets shall be made with 16 mm thick BWP grade marine plywood of approved make conforming to IS 710 and glass shutters shall be with 5.5 mm thick float glass with approved design and approved method of fixing etc. complete.		

	<p>Pullouts/ Drawers Each pullout/drawer made with 16 mm thick BWP grade marine plywood of approved make conforming to IS 710 for facia and approved quality and make SS 304 baskets/ accessories (Hetich, Ebco, Sleek or approved equivalent make) shall be mounted on approved quality high precision soft closing type telescopic channels (to be designed as per drawer size and weight) and fixed to the vertical ply wood panel to ensure smooth movements and provided with approved quality SS brush finished handles (minimum 100mm long) Shelves Shelves (minimum one intermediate shelf per cabinet) in the below counter cabinets shall be made with 16 mm thick BWP grade marine plywood of approved make conforming to IS 710 with 2 mm thick P.V.C edge banding. Those in the OH cabinet shall be made out of 10mm thick clear float glass with machine polished edges. All shelves shall be supported on approved quality SS pins and shall be adjustable for various height requirements</p>		
	<p>Following accessories of SS 304 grade shall be provided - Cup & saucer baskets - 01 No, Plain baskets - 05 Nos, Dustbin holder – 01 No, Glass & plate tray – 01 No, Powder coated Tandem box - 6 Nos.</p>		
	<p>TALL UNIT: Tall unit having approximate dimensions - 900 x 550 x 1900 mm. The carcass and double shutters of the tall unit including racks at bottom intermediate levels etc shall be made with 16 mm thick BWP grade marine plywood of approved make conforming to IS 710. The back panel of the unit shall be made with 12mm thick ply of same grade. The glass shutters shall be with 6mm thick float glass and top intermediate glass racks (3 Nos) are with 10mm thick float glass of approved make. Each shutter shall be fixed to the carcass using four numbers of best quality EURO type Slip-in Hinge and provided with an approved quality and profile brush finished SS handle (minimum 100mm long)</p>		
	<p>KITCHEN SINK Supplying and fixing stainless steel sink with drain board of overall size 915 x 460 mm with bowl size 16" x 14" x 7.5", satin finish, conforming to SS 304 grade/1mm thick of approved make, making grooves in the granite to fix the sink including the joints with granite slab shall be sealed thoroughly with epoxy/ silicon sealant, including all necessary fittings and fixtures, CP waste coupling, PVC flexible waste pipe etc all complete as directed.</p>		
	<p>Providing and making shutters with framework to the open area above overhead cabinets (approx. elevation dimensions of 2500mm x 750mm) and cabinet with shutters above 2100mm level having approx. dimensions 2430mm x 500mm x 750mm made with 16 mm thick BWP grade marine plywood of approved make. The framework/ cabinets shall firmly fix to the ceiling, sides, etc. suitable type fasteners etc. The shutters are fixed to the frame with auto closing SS hinges (2 nos each per shutter). b) The external surfaces of shutters and cabinet are pasted with 1 mm thick decorative laminate of approved make and shade and the entire interior surfaces are pasted with 0.80 mm thick laminate of approved make and all the exposed edges shall be pasted with edge banding of suitable size etc. including providing 150mm long SS handles (1 each per shutter), magnetic catches etc all complete</p>		

	<p>The units shall be firmly fixed to the walls/ slabs/floor using metal screws of appropriate size and rawl plugs/ nylon sleeves / levelling screws. Legs of below counter units shall be of ABS plastic and with PVC detachable skirting. The legs and the PVC detachable skirting should be fixed with an inset of at least 25 mm from the outermost level of cabinet-shutters. All exposed surfaces of the plywood used in the work viz. carcass, shutter, pull out drawer, shelves including overhead and below the counter units except post formed shutters shall be laminated on both sides with 1 mm thick laminate (0.80mm thick laminate for inside area of shutters and boxes) of approved make and shade (by factory pressing using laminates of approved make and shade and approved quality and make synthetic resin-based adhesives. All edges of the plywood shall be provided with 2 mm thick P.V.C edge banding of approved quality and make (by factory pressing and using approved quality and make synthetic resin-based adhesives). The shutters provided for the space below kitchen sink and gas cylinder compartment shall be fitted with approved quality and design, wooden/ SS 304 louvers to ensure proper ventilation.</p>	1.00	Job
35	<p>Providing and fixing 25 mm dia heavy duty SS drapery rods for windows/ doors openings with brackets/ fixing arrangements and ornamental knobs of approved brand/ design etc. complete all as per specifications and as directed by Bank's Engineer.</p>	26.00	Rmtr
36	<p>Providing, fabricating and fixing openable/ removable type mosquito net panels for windows in flats with following specifications. Outer frames of 1.25" square pipe and shutter frames of overall size 25x15mm for each panel shall be made with approved quality and make aluminium extruded built-up standard sections / appropriate Z sections and finished with powder coating of approved shade. The mesh panels shall be of approved make SS square mesh with powder coated finish in single piece fixed to the frame with EPDM rubber beading in approved methods etc. Each panel shall be provided with one intermediate horizontal frame of suitable size also. The Contractor shall produce samples for Bank's approval before using the same in the work. Materials approved by the Bank shall only be used in the work. The rates shall be inclusive of providing necessary nylon hinges and locking arrangements for shutters, etc all complete as directed by the Bank's Engineer.</p>	18.00	Sqm
37	<p>Upgradation of main door with frame: Carefully removing the existing door shutter, hardware fittings etc., thoroughly scrapping and removing the paint finishes on the shutter and frame, providing and pasting 4 mm thick veneer of approved make and shade to the shutter panels and door frame by approved means, providing and fixing decorative teak wood beadings for the shutter panels and door frame etc. complete. The rate shall include for providing and applying required no. of coats of melamine spray polish (semi glossy polish) of approved shade and quality to the entire face of the modified door shutter and door frame, providing and fixing new hardware like SS matt finish hinges, heavy duty SS matt finish handles, aldop, tower bolts etc. of required no. and size, verti-bolt lock etc all complete as directed by the Bank's Engineer.</p>	1.00	Job

38	Carefully removing the existing door shutters from the frame, removing all the existing hardware fittings, carryout minor repairs, cutting the bottom of the shutters, if necessary to adjust the height suitable for new flooring, re-fixing the doors to the door frame with new SS matt finish hinges etc. The rate shall inclusive of providing and fixing new hardware like SS matt finish handles, aldrop, tower bolts etc. of required no. and size, etc all complete as directed by the Bank's Engineer. Total no. of doors to be taken up for work in the flat is 7 Nos.	1.00	Job
39	Repainting the entire interior area of flat by preparing the surface of the walls, ceiling and soffits or vertical sides of the beams, wood and metal surfaces, etc by scrapping, sand papering & dusting of loose paints/ paint flakes etc., providing and applying: (1) One coat of cement primer and two coats of OBD to ceiling etc. (Area per flat: 102.73 Sq.mt). Two coats of fully putty to be applied ceiling in hall area (26 Sqm) (2) Providing and applying two coats of acrylic premium interior emulsion paint of approved make and shade to the walls, beams, etc. over a coat of primer and putty work wherever required (Area per flat: 283 Sqm). Two coats of fully putty to be applied for walls in hall area (74 Sqm) (3) Two coats of 1st quality Synthetic enamel paint (satin finish) of approved make and shade to wood surfaces of doors, windows, etc. (Area per flat: 50.36 Sq.m) (4) Two coats of 1st quality synthetic enamel paint (satin finish) of approved make and shade to steel work, viz. window & balcony grills etc including surface preparation, complete as directed. (Area per flat: 16 Sq.mt) 5) Thorough cleaning of the entire floor, wall tiles, kitchen counter, skirting, switch boards etc.	1.00	Job
40	Rebate for taking away the salvageable items removed and stacked as per item No. 1 – Rate inclusive of GST	1	LS

Date:
Place:

Signature of the Tenderer with seal:

ANNEXURE I

करार की शर्तें/ ARTICLES OF AGREEMENT (FOR REFERENCE ONLY)

-----के ----- दिन पर करार की शर्तें एक पार्टी भारतीय रिज़र्व बैंक (यहाँ इसके बाद जिसे "नियोक्ता" कहा गया है) और दूसरी पार्टी -----
----- (यहाँ इसके बाद जिसे "संविदाकार" कहा गया है) के बीच निर्धारित की गई हैं।

ARTICLES OF AGREEMENT made the----- day of-----, between the Reserve Bank of India (hereinafter called the Employer) of the one part and ----- (hereinafter called "the contractor") of the other part.

जब कि नियोक्ता तमलम स्थित बैंक के स्टाफ क्वार्टर्स में अधिकारी फ्लैट (E-08) के नवीकरण करवाने का इच्छुक है और बैंक के इंजीनियर के निदेशानुसार किये जाने वाले कार्य का वर्णन करते हुए मात्रा का बिल, रेखाचित्र एवं विनिर्देश तैयार किये हैं।

WHEREAS the Employer is desirous of taking up the work of Renovation of Officer flat (E-08) at Bank's Staff quarters, Thamalam, Thiruvananthapuram and has prepared Bill of Quantities, drawings showing and describing the work to be done under the direction of Bank's Engineer.

और जबकि विनिर्देशों, मात्रा - अनुसूची पर अब से पार्टियों द्वारा अथवा उनकी ओर से हस्ताक्षर किये गये हैं।

AND WHEREAS the specifications and the schedule of Quantities have been signed by or on behalf of the parties hereto.

और जब कि संविदाकार ने इसमें घोषित शर्तों के अधीन और विशेष शर्तों में बताई गई शर्तों और मात्रा अनुसूची और संविदा की यथा संशोधित और दोनों पार्टियों द्वारा अंतिम रूप से स्वीकृत शर्तों (उन सभी को यहाँ इसके बाद सामूहिक रूप से "उक्त शर्तें" कहा गया है) पर ऊपर उक्त रेखाचित्रों में दर्शाये गये और/अथवा उक्त विनिर्देशों में वर्णित और उसमें घोषित संबंधित दरों पर मात्रा अनुसूची में शामिल करके निकाली हुई राशि और ऐसी अन्य राशि पर जो उसके अंतर्गत भुगतान योग्य होगी (यहाँ इसके बाद जिसे "उक्त संविदा राशि" कहा गया है) कार्य का निष्पादन करने की सहमति प्रदान की है।

AND WHEREAS the Contractor has agreed to execute upon and subject to the conditions set forth in the conditions and in the Schedule of Quantities and Conditions of Contract (all of which are collectively hereinafter referred to as "the said Conditions") the work shown upon or described in the said Specifications and included in the Schedule of Quantities in the respective rates therein set forth amounting the sum as therein arrived or such other sum as shall become payable there under (hereinafter referred to as "the said contractor amount").

अब इसके द्वारा निम्नानुसार यह सहमति हुई है/ NOW IT IS HEREBY AGREED AS FOLLOWS:-

1. उक्त शर्तों में बताई गई विधि और समय-समय पर भुगतान की जाने वाली उक्त संविदा राशि को ध्यान में रखते हुए संविदाकार उक्त शर्त पर और शर्त के अधीन ऊपर दर्शाए गए रेखाचित्रों और उक्त विशेष विवरणों तथा मात्रा-अनुसूची में वर्णित कार्य को निष्पादित और पूर्ण करेगा।

In consideration of the said Contract amount to be paid at the times and in the manner set forth in the said conditions, the Contractor will upon and subject to the conditions annexed carry out and complete the work shown upon the contract drawings and described by or referred to in the Schedule of Quantities and in the said conditions.

2. नियोक्ता संविदाकार को उक्त संविदा राशि अथवा ऐसी अन्य राशि का भुगतान करेगा जो समय-समय पर और उक्त शर्तों में विनिर्दिष्ट विधि से भुगतान योग्य होगी।

The Employer will pay the Contractor the said contract Amount, or such sum as shall become payable, at the times and in the manner specified in the said conditions.

3. भारतीय रिज़र्व बैंक कार्य के पर्यवेक्षण, बिलों के प्रमाणन, भुगतान और विभिन्न शर्तों के कार्यान्वयन, संविदा की शर्तों के प्रबंध और प्रत्यक्ष पर्यवेक्षण की व्यवस्था करेगा।

The Reserve Bank of India will administer and directly arrange for supervision of works, certification of bills, making payments and implementation of various terms, conditions and stipulations of the contract.

4. उक्त शर्तों और संबंधित परिशिष्ट इस करार के भाग के रूप में पढ़े और समझे जाएंगे और उस संदर्भ में पार्टियाँ अब से इसमें निहित उक्त शर्तों के प्रति प्रतिबद्ध रहेगी, उनके प्रति अपने आपको समर्पित करेगी तथा अपनी-अपनी ओर से करारों का निष्पादन करेगी।

The said Conditions and Appendix thereto and the correspondence attached hereto shall be read and construed as forming part of this Agreement and the parties hereto shall respectively abide by, submit themselves to the said Conditions and the correspondence and perform the agreement on their part respectively in the said Conditions and the correspondence contained.

5. उक्त नक्शे, करार और इसमें उल्लिखित दस्तावेज़ इस संविदा का आधार होंगे।

The plans, agreement and documents mentioned herein shall form the basis of this contract.

6. यह संविदा न तो एक एकमुश्त संविदा है और न ही एक मद वार उजरती काम है बल्कि यह एक ऐसी संविदा है जिसके अंतर्गत उक्त कार्य पूरा करना है और उसके लिए दरों की अनुसूची में निहित दरों और संभावित मात्राओं की अनुसूची में दी गई दरों पर वास्तविक रूप से मापी गई मात्राओं अथवा उक्त शर्तों में यथा निर्धारित दरों के अनुसार भुगतान किया जाना है।

This contract is neither a fixed Lump Sum Contract nor a Piece Work Contract, but it is a Contract for the complete work to be paid for according to actual quantities at the rates contained in the Schedule of Rates and Probable Quantities or as provided in the said Conditions.

7. संविदाकार उक्त शर्तों में निर्धारित की गई विधि से सिविल कार्यों और अनुषंगी कार्यों से संबंधित समस्त कार्यों को पूरा करने के लिए सभी उचित सुविधाएं प्रदान करेगा और ऐसा कार्य पूर्ण होने के बाद दीवारों, फर्श, इत्यादि को हुई किसी प्रकार की क्षति को ठीक कराएगा।

The Contractor shall afford every reasonable facility for carrying out of all works or other Contractors appointed by the Employer and shall make good any damages done to walls, floors, etc. after the completion of such works.

8. नियोक्ता के पास यह अधिकार सुरक्षित है कि वह संविदा के चालू रहने के दौरान किसी भी समय, इस संविदा पर प्रतिकूल प्रभाव डाले बिना कार्य की किसी मद को जोड़ कर अथवा हटा कर उसके रेखाचित्र और कार्य के प्रकार में परिवर्तन कर दे अथवा उसके भागों को पूर्ण करवा ले। तथापि, ठेकेदार निविदा राशि से अधिक किए गए कार्यों के लिए किसी भी भुगतान के हकदार नहीं होंगे, जब तक बैंक के इंजीनियर द्वारा विशेष रूप से लिखित अनुमोदन प्राप्त नहीं किया जाता है।

The Employer reserves to itself the right of altering the items to be executed by adding to or omitting any items without prejudice to this contract. However, the Contractor shall not be entitled to any payment for the works done exceeding the Tender Quantities unless specifically approved in writing by the Bank's Engineer.

9. 'समय इस संविदा का महत्वपूर्ण कारक है और संविदाकार एतद्वारा सहमत है कि समय विस्तार का प्रावधान होते हुए भी वह कार्य आदेश जारी करने की दिनांक से दसवें दिन से तथाकथित शर्तों में उल्लिखित किए गए अनुसार जो भी बाद में हो, काम शुरू कर देगा और उसके बाद कार्य आदेश की तारीख के 10 वें दिन से 9 हफ्ते की अवधि के भीतर पूरा काम करेगा। यदि कार्य को कार्य आदेश में निर्धारित समय के भीतर पूरा नहीं किया जाता है, तो अनुबंधित मूल्य के अधिकतम 10% विलंबित विषय के प्रति सप्ताह अनुबंध राशि के 0.25% की दर से परिसमापन किया जाएगा। इस संविदा के अंतर्गत नियोक्ता द्वारा किये गये सभी भुगतान केवल तिरुवनंतपुरम में ही किये जाएंगे।

Time shall be considered as the essence of this Contract and the contractor hereby agrees to commence the work from tenth day of the date of issue of work order as provided for in the said Conditions and to complete the entire work within a period of nine weeks from the 10th day of date of work order subject nevertheless to the extension of time granted by the Bank. If the work is not completed within the time stipulated in the Work Order, Liquidated Damages at the rate of 0.25% of the contract amount per week of delay subject to a maximum of 10% of the contract value will be levied.' All payments by the Employer under this Contract will be made only at Thiruvananthapuram.

10. इस संविदा के अंतर्गत नियोक्ता द्वारा सभी भुगतान केवल तिरुवनंतपुरम में किए जाएंगे।

All payments by the Employer under this Contract will be made only at Thiruvananthapuram.

11. इस करार से उत्पन्न अथवा किसी भी प्रकार से इससे संबंधित सभी विवादों के संबंध में यह समझा जाएगा कि वे तिरुवनंतपुरम में उठे हैं और उनके संबंध में निर्णय के लिए केवल तिरुवनंतपुरम के न्यायालय ही न्यायक्षेत्र होंगे।

All disputes arising out of or in any way connected with this Agreement shall be deemed to have arisen at Thiruvananthapuram and only Courts in Thiruvananthapuram shall have the jurisdiction to determine the same.

12. यह कि संविदाकार द्वारा इस संविदा के विभिन्न भागों को पढ़ा गया है और उन्हें संविदाकार द्वारा पूरी तरह से समझ लिया गया है।

That the several parts of this agreement have been read by the contractor and fully understood by the contractor.

13. संविदाकार इस करार के संबंध में अपने संविदात्मक दायित्वों को पूरा करने के दौरान ठेकदार को मिलने वाली कोई भी जानकारी, सामग्री तथा बैंक के बुनियादी ढांचा/सिस्टम/उपस्करों आदि के संबंध में मिलने वाली जानकारी का प्रत्यक्ष या अप्रत्यक्ष रूप से प्रकटीकरण किसी अन्य पक्षकार को नहीं करेगा तथा हमेशा इसे अतिगोपनीय बनाए रखेगा। लागू कानून का अनुपालन करने या संविदा के अधीन अपने दायित्वों को पूरा करने के लिए आवश्यक होने की स्थिति को छोड़कर संविदाकार इस संविदा के ब्यौरों को निजी दायरे में और गोपनीय रखेगा। बैंक की पूर्व लिखित अनुमति के बिना संविदाकार किसी व्यापारिक या तकनीकी पेपर में या अन्यत्र कार्य के विवरण को न तो प्रकाशित करेगा, न ही प्रकाशन की अनुमति देगा और न ही इसका प्रकटीकरण करेगा। किसी गोपनीय जानकारी के प्रकटीकरण के परिणामस्वरूप बैंक को हुई हानि के लिए संविदाकार बैंक को क्षतिपूर्ति करेगा। उपर्युक्त शर्तों का पालन न करना संविदाकार द्वारा संविदा भंग माना जाएगा और नियोक्ता हुई क्षति का दावा करने तथा कानूनी उपाय करने का हकदार होगा।

इस करार के अधीन गोपनीय जानकारी का प्रकटीकरण न किए जाने के दायित्व को सुनिश्चित करने के लिए संविदाकार अपने कर्मचारियों के संबंध में सभी उचित कार्रवाई करेगा।

प्रकटीकरण न करने और गोपनीयता के संबंध में संविदाकार का दायित्व इस करार के समाप्त होने या किसी भी कारण से समाप्त किए जाने तक बना रहेगा।

The Contractor shall not disclose directly or indirectly any information, materials and details of the Bank's infrastructure/systems/equipment etc., which may come to the possession or knowledge of the Contractor during the course of discharging its contractual obligations in connection with this agreement, to any third party and shall at all times hold the same in strictest confidence. The Contractor shall treat the details of the contract as private and confidential, except to the extent necessary to carry out the obligations under it or to comply with applicable laws. The Contractor shall not publish, permit to be published, or disclose any particulars of the works in any trade or technical paper or elsewhere without the previous written consent of the Employer. The Contractor shall indemnify the Employer for any loss suffered by the Employer as a result of disclosure of any confidential information. Failure to observe the above shall be treated as breach of contract on the part of the Contractor and the Employer shall be entitled to claim damages and pursue legal remedies.

The Contractor shall take all appropriate actions with respect to its employees to ensure that the obligations of non-disclosure of confidential information under this Agreement is fully satisfied. The Contractor's obligations with respect to non-disclosure and confidentiality will survive the expiry or termination of this agreement for whatever reason.

14.विदाकार संविदा श्रम (विनियमन और उन्मूलन) अधिनियम 1970 और इसके अंतर्गत बनाए गए सभी नियमों का पालन करेगा और इसके अंतर्गत सभी आवश्यकताओं को पूरा करेगा। संविदाकार किसी एक दिन कार्य पर लगाए जाने वाले अधिकतम मजदूरों की संख्या के बारे में बैंक को बताएगा। इस संख्या में होने वाली वृद्धि को बिना किसी देरी के बैंक को बताया जाए। यदि कार्य के लिए लगाए जाने वाले मजदूरों की संख्या बीस या उससे अधिक होती है तो संविदाकार क्षेत्रीय श्रम आयुक्त से लाइसेंस प्राप्त करेगा। संविदाकार अपने द्वारा काम पर लगाए गए सभी मजदूरों/कामगारों को न्यूनतम मजदूरी का भुगतान सुनिश्चित करेगा।

The contractor shall abide by and fulfill all requirements laid down under the Contract Labour (Regulation and Abolition) Act, 1970 and the rules framed there-under. The contractor shall submit to the Bank the maximum number of Labours to be engaged on a single day in the job. Any subsequent increase should be informed to the Bank without delay, if the number of labourers employed for the job are twenty or more, the contractor shall obtain the license from the Regional Labour Commissioner. The contractor should ensure payment of minimum wages to all labourers/workmen staff employed by him.

15.क) संविदाकार कार्यस्थलों पर महिलाओं का यौन उत्पीड़न (रोकथाम, निषेध और निवारण) अधिनियम, 2013 ("अधिनियम") के प्रावधानों का पूर्ण अनुपालन करने के लिए पूरी तरह जिम्मेदार होंगे। भारतीय रिज़र्व बैंक (चेन्नै कार्यालय) के परिसर के भीतर अपने कर्मचारी के खिलाफ यौन उत्पीड़न की किसी भी शिकायत के मामले में शिकायत संविदाकार/एजेंसी द्वारा गठित शिकायत समिति के समक्ष दायर की जाएगी संविदाकार/एजेंसी उक्त शिकायत के संबंध में अधिनियम के अंतर्गत समुचित कार्रवाई सुनिश्चित करेगा।

ख. संविदाकार के किसी पीड़ित कर्मचारी द्वारा बैंक के किसी कर्मचारी के विरुद्ध की गई यौन उत्पीड़न की किसी भी शिकायत का संज्ञान बैंक द्वारा गठित क्षेत्रीय शिकायत समिति द्वारा लिया जाएगा।

ग. यदि घटना में संविदाकार का कोई कर्मचारी शामिल होता है तो उस स्थिति प्रदान की जाने किसी भी मौद्रिक प्रतिपूर्ति के लिए संविदाकार उत्तरदायित्व होगा, उदाहरण के लिए बैंक के किसी कर्मचारी को दी जाने वाली मौद्रिक राहत यदि संविदाकार के कर्मचारी द्वारा यौन हिंसा सिद्ध हो जाती है।

घ. कार्यस्थल पर यौन उत्पीड़न की रोकथाम और अन्य संबंधित मुद्दों पर अपने कर्मचारियों को शिक्षित करने की जिम्मेदारी संविदाकार की होगी।

ङ. संविदाकार बैंक परिसर में काम पर लगाए गए अपने कर्मचारियों की पूरी और अद्यतन सूची उपलब्ध करवाएगा।

a) The contractor/ agency shall be solely responsible for full compliance with the provisions of "the Sexual Harassment of women at workplace (Prevention, Prohibition and Redressal) Act, 2013". In case of any complaint of sexual harassment against its employee within the premises of the Bank, the complaint will be filed before the Internal Complaints Committee constituted by the Contractor/ Agency and the Contractor/Agency shall ensure appropriate action under the said Act in respect of the complaint.

b) Any complaint of sexual harassment from any aggrieved employee of the contractor against any employee of the Bank shall be taken cognizance of by the Regional Complaint Committee constituted by the Bank.

c) The contractor shall be responsible for any monetary compensation that may need to be paid in case the incident involves the employees of the contractor, for instance any monetary relief to the Bank's employee, if sexual violence by the employee of the contractor is proved.

d) The contractor shall be responsible for educating its employees about prevention of sexual harassment at workplace and related issues.

e) The contractor shall provide a complete and updated list of its employees who are deployed within the Bank's premises.

16. संविदाकार निम्न के संबंध में भारतीय रिज़र्व बैंक के पक्ष में बीमा करवाएगा और उसे लागू रखेगा

- i) कार्य के निष्पादन से/दौरान होने वाली तीसरी पार्टी के नुकसान/ व्यक्ति या संपत्ति को हुए नुकसान से उत्पन्न दावा।
- ii) कार्य के निष्पादन के दौरान संविदाकार द्वारा काम पर लगाए गए कामगार के कारण हुए नुकसान/क्षति से उत्पन्न दावा।
- iii) लागू पीएफ/श्रम कानूनों, ईएसआई, विनियमों आदि का अनुपालन न किए जाने के कारण उत्पन्न कोई दावा।

The Contractor shall indemnify and keep indemnified the RESERVE BANK OF INDIA against:

- i) Any claim arising out of third-party loss/ damage to life or property caused by/during execution of the work.
- ii) Any claim arising out of loss/ damage to the workmen engaged by the contractor during execution of the work.
- iii) Any claim due to non-compliance of applicable PF/ Labour laws, ESI, regulations etc

नियोक्ता और संविदाकार इस बारे में साक्ष्य स्वरूप अपने-अपने हस्ताक्षर किए और इसकी दो प्रतियाँ उक्त दिन और वर्ष को तैयार की गईं।

IN WITNESS WHEREOF the Employer and the Contractor have set their respective hands to these presents and two duplicates hereof the day and year first hereinabove written.

यदि संविदाकार एक साझेदारी फ़र्म या एक व्यक्ति हो

If the contractor is a partnership or an individual.

नियोक्ता और संविदाकार इस बारे में साक्ष्य स्वरूप अपने-अपने अधिकृत हस्ताक्षरकर्ताओं के माध्यम से निष्पादित किए और संविदाकार ने इसकी दोनों प्रतियों पर अपनी सामान्य मुहर लगाई इसकी दो प्रतियों पर उसकी ओर से इन्हें उक्त दिन और वर्ष को निष्पादित किया गया।

IN WITNESS WHEREOF the Employer has set its hands to these presents through its duly authorized official and the Contractor has caused its common seal to be affixed hereunto and the said duplicate/ has caused these presents and the said two duplicate hereof to be executed on its behalf, the day and year first hereinabove written.

यदि संविदाकार एक कंपनी है तो

If the contractor is a company.

हस्ताक्षर खंड Signature Clause

भारतीय रिज़र्व बैंक की ओर से हस्ताक्षरित एवं सुपुर्द
SIGNED AND DELIVERED by the Reserve bank of
India by the hand of
श्री / Shri

(नाम एवं पदनाम) / (Name and designation)

इनकी उपस्थिति में हस्ताक्षर किये गए / In the presence
of

(1)

पता / Address

(2)
पता / Address

साक्षी / Witness

SIGNED AND DELIVERED by

इनकी उपस्थिति में हस्ताक्षर किये गए / In the presence of

(1)
पता / Address

(2)
पता / Address

साक्षी / Witness

THE COMMON SEAL OF

निम्नलिखित की उपस्थिति में दिनांक ----- को संपन्न
निदेशक बोर्ड की बैठक में पारित संकल्प के अनुसरण में इस
पर ----- की कॉमन मुहर लगाई गई है।

Was hereunto affixed pursuant to the resolutions
passed by its Board of Directors at the meeting held
on _____ in the presence of

(1)
(2)

निदेशक, जिन्होंने निम्नलिखित की मौजूदगी में इसके
प्रमाणस्वरूप इन दस्तावेजों पर हस्ताक्षर किए हैं।

Directors who have signed these presents in token
thereof in the presence of

(1)
(2)

विधिवत गठित अटर्नी एवं श्री

द्वारा हस्ताक्षरित एवं सुर्पुद

SIGNED AND DELIVERED BY the Contractor by
the _____ hand of _____ Shri
_____ and duly
constituted attorney.

यदि पार्टी भागीदारी फर्म या
वैयक्तिक फर्म हो तो सभी अथवा
सभी भागीदारों की ओर से
हस्ताक्षर किये जाने चाहिए।

If the party is partnership firm
or an individual should be
signed by all or on behalf of all
the partners.

यदि निविदाकार उसके कॉमन
मुहर के अंतर्गत हस्ताक्षर करता
है तो हस्ताक्षर खंड संस्था के
अन्तर्नियमों में दिए गए मुहर खंड
से मेल खाने चाहिए।

If the Contractor signs under its
common seal, the signature
clause should tally with the
sealing clause in the Articles of
Association.

यदि संविदाकार चाहे कंपनी के
रूप में या वैयक्तिक रूप में
मुख्तारनामा के अंतर्गत हस्ताक्षर
करता हो तो

If the Contractor is signing by
hand of power of Attorney,
whether a company or
individual.

Annexure II

Undertaking regarding debarment

(To be submitted by the tenderer in their letterhead)

Name of Work:

1. I/We (Name of the bidder) declares that
 - a) I/we or any of our allied firm* is/ are not debarred / suspended / blacklisted by any public institution/entity in India or any other country as on(Last date of submission of bid).
 - b) I/We or any of our allied firm* have not made any transgression in respect of the code of integrity (as mentioned in the tender) with any public institution/entity in india or any other country in last three years as on(Last date of submission of bid)
 - c) We will inform the Bank in writing, in case, I/we or any of our allied firm* is/are debarred/suspended/blacklisted by any public institution in india or any other country on or before award of work for the captioned work.

2. I/We, (Name of the bidder) declare that I/we or our allied firm * (Name of the allied firm(s) is/are debarred/suspended/blacklisted by (Name and address of public institution in India or any other country) and the same effective up to(date). A copy of such letter is attached for your information and record.

(Seal and signature of the bidder)

Date

Place

(Note: strike out one of the above two declarations which is not applicable)

*Allied firm: A firm would be termed as “allied firm” if the management is common, or substantial or majority shares are owned by the banned/ suspended firm and by virtue of this it has a controlling voice. Further all successor firms will also be considered as allied firm.

Annexure-III (Drawings)

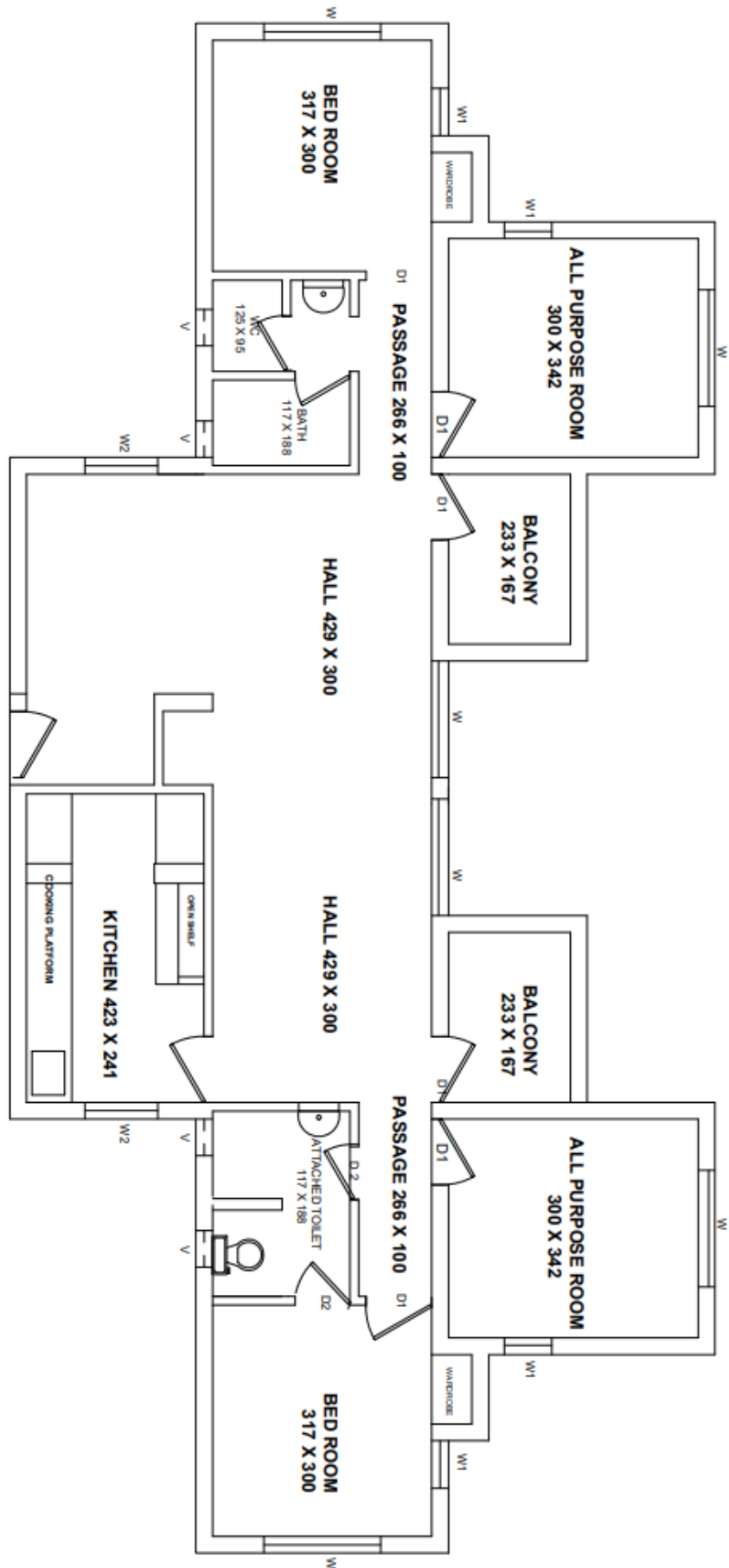

**OFFICER TYPE FLAT AT THAMMALAM
EXISTING LAYOUT**

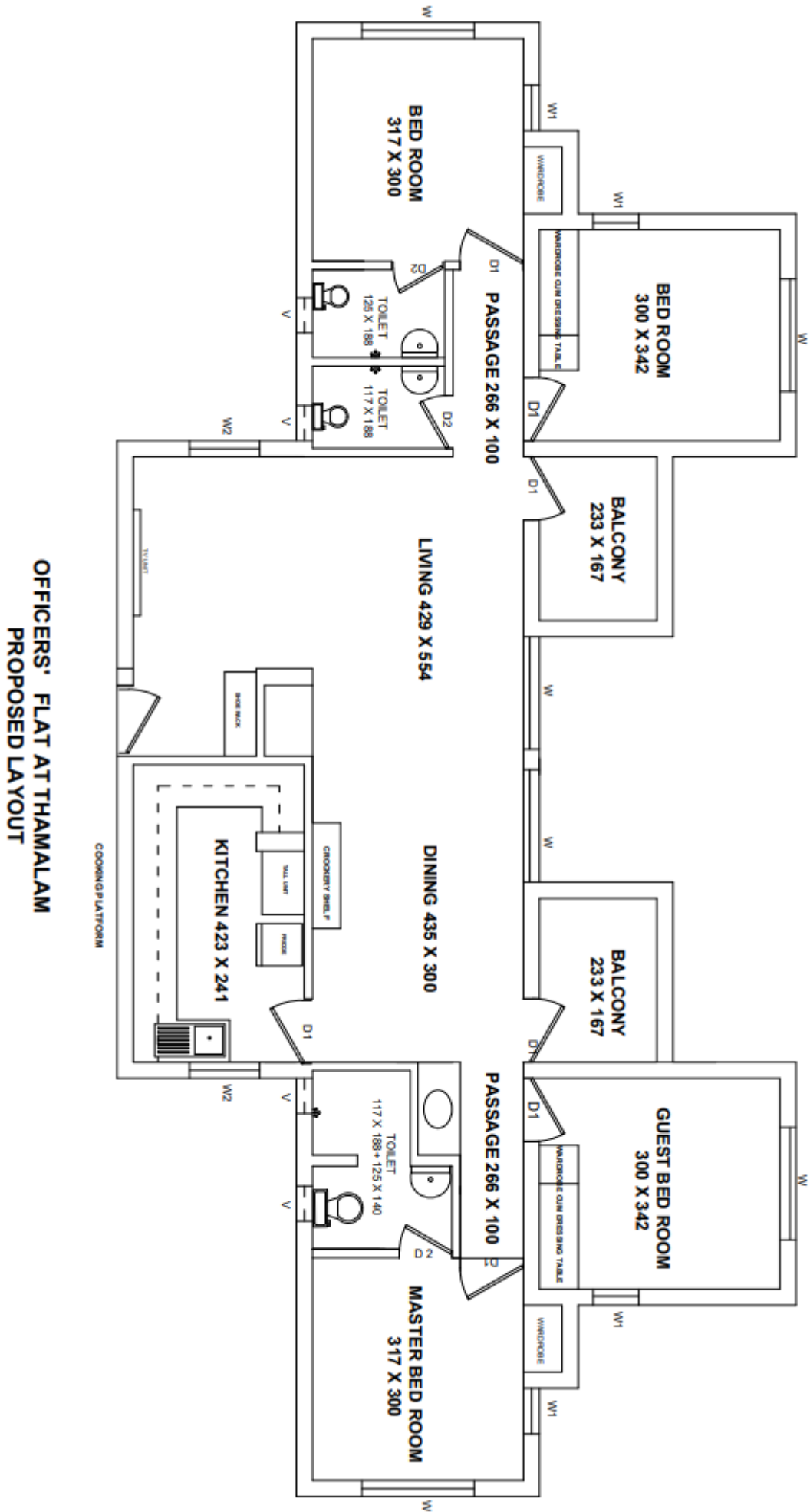

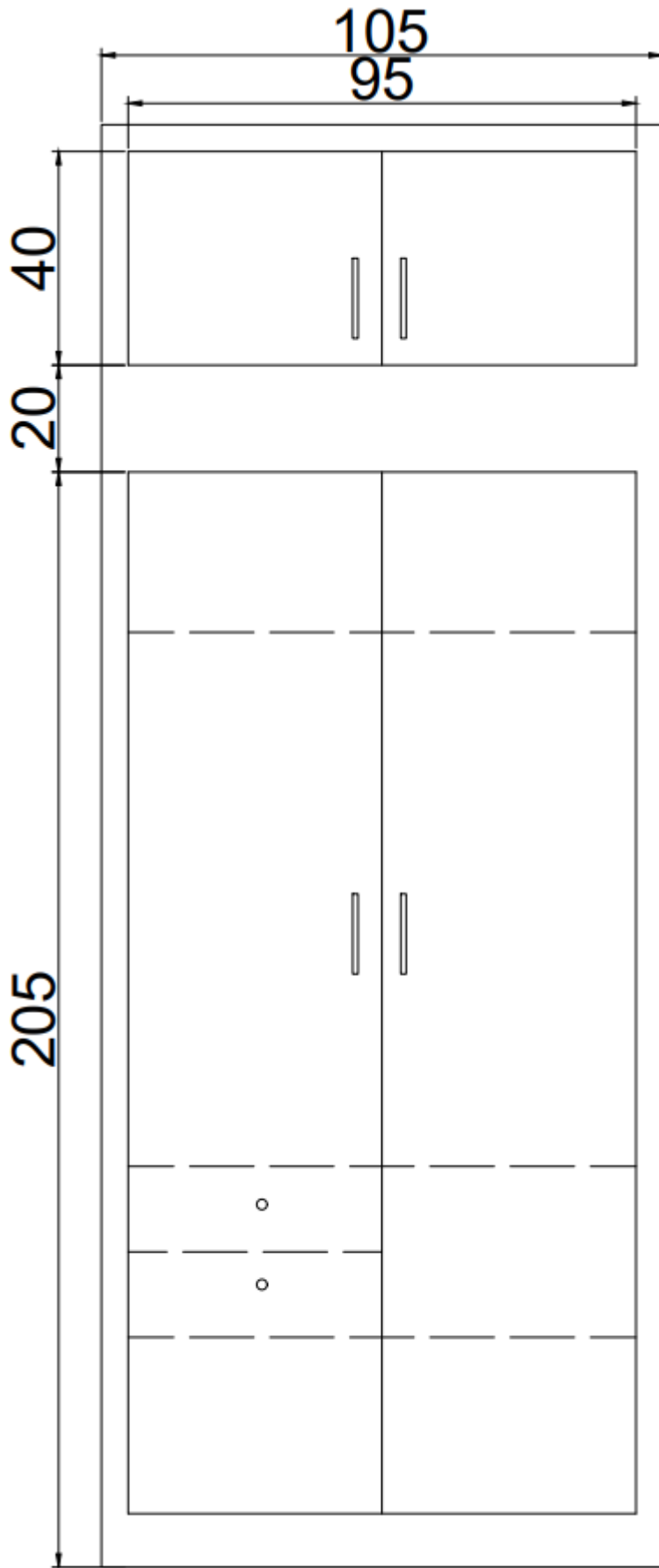

WARDRBE DETAILS

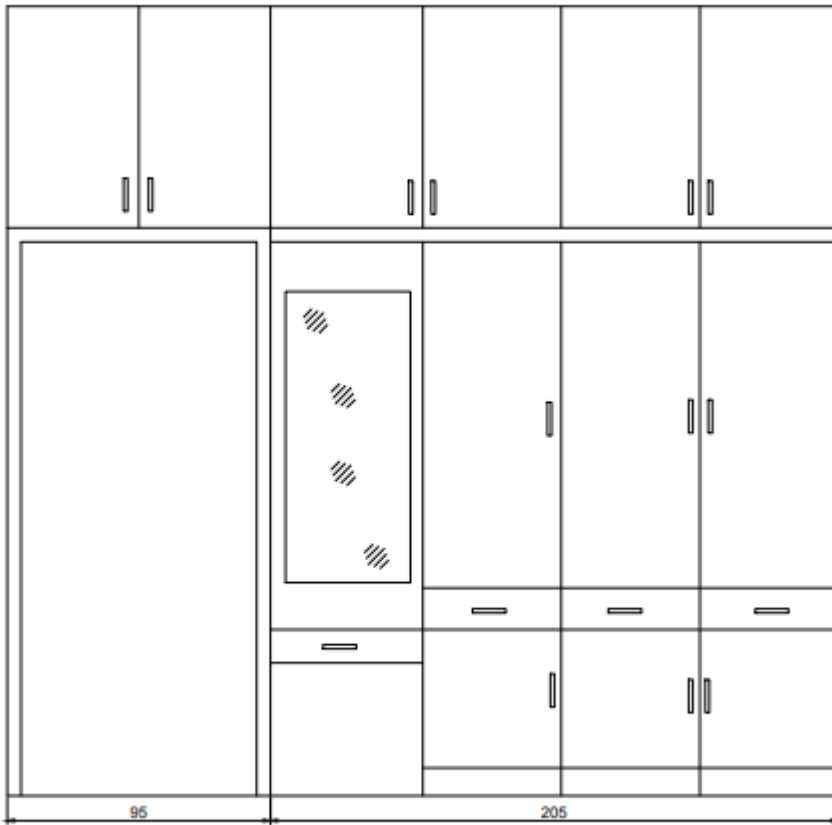

WARDROBE - 2 - VIEW WITH SHUTTERS

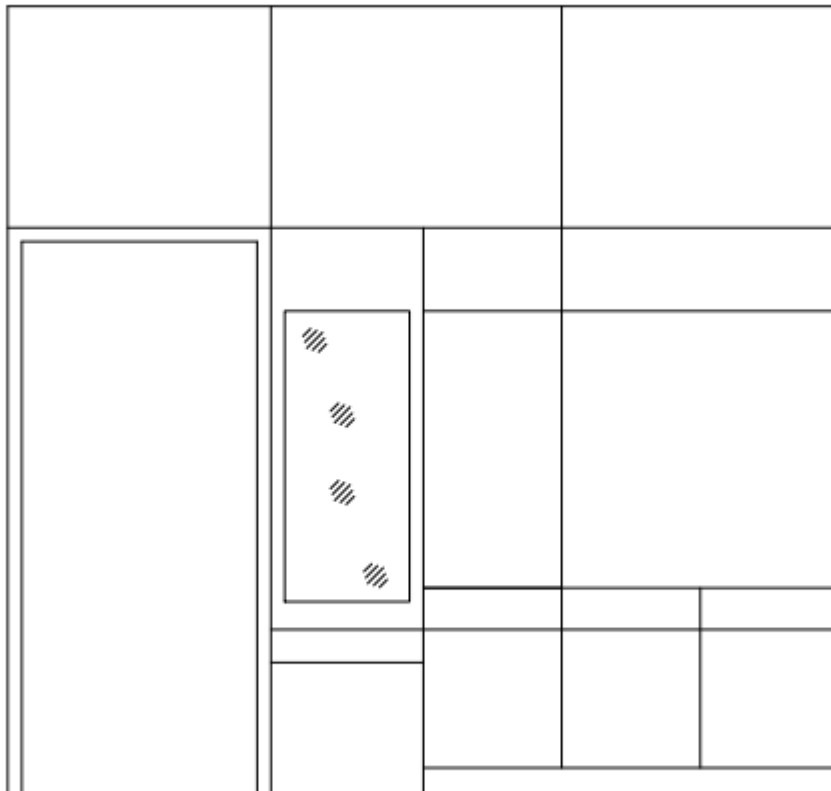

WARDROBE - 2 - VIEW WITHOUT SHUTTERS

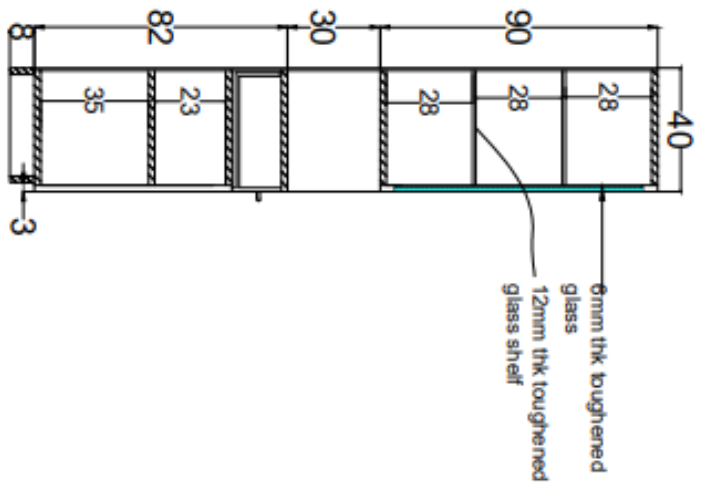
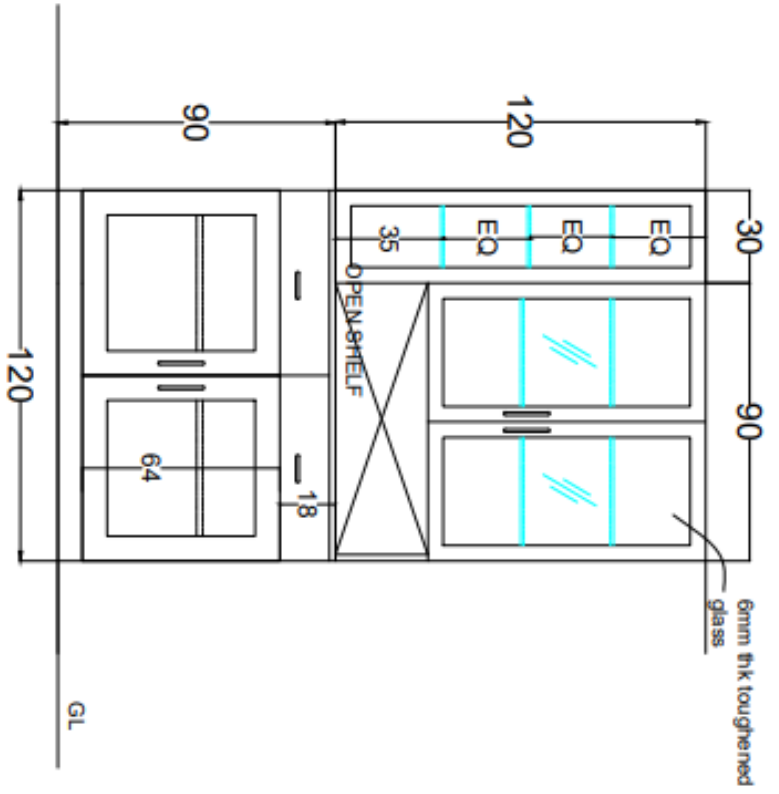

ELEVATION

SECTION AA'

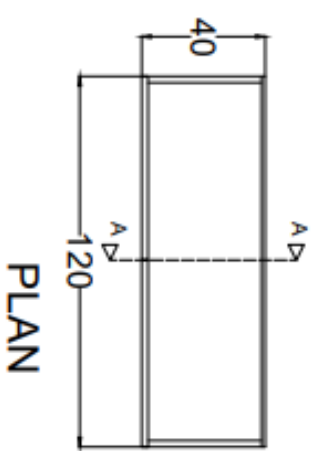

PLAN

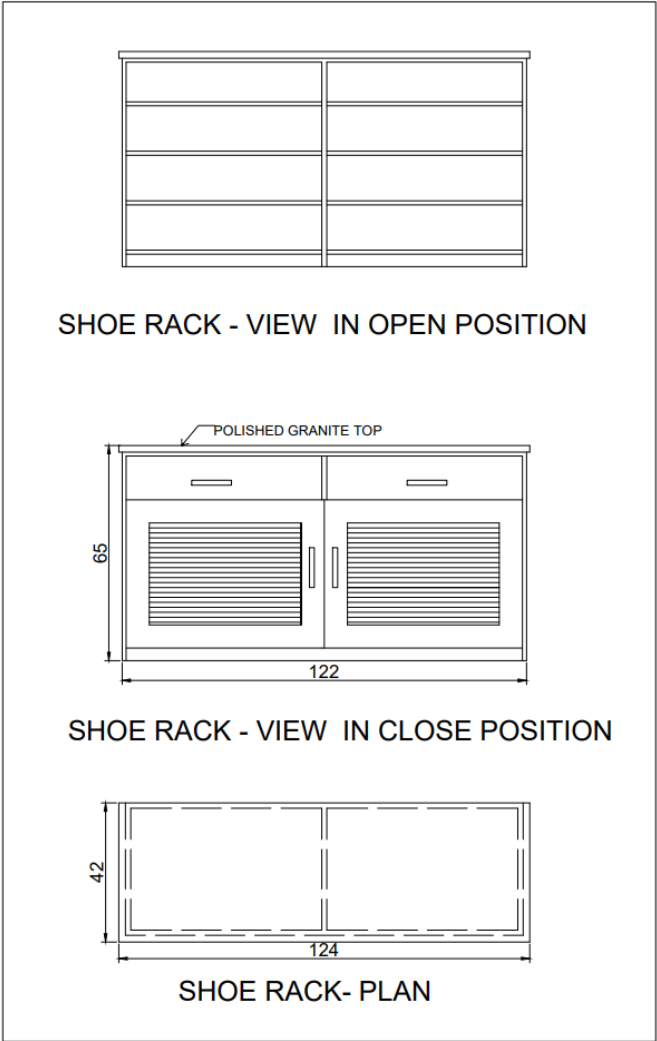
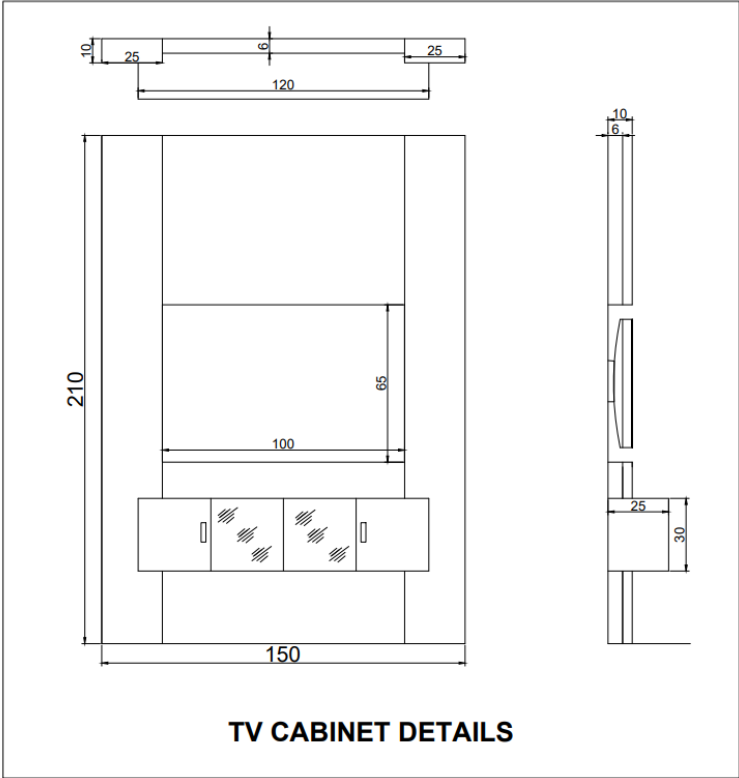

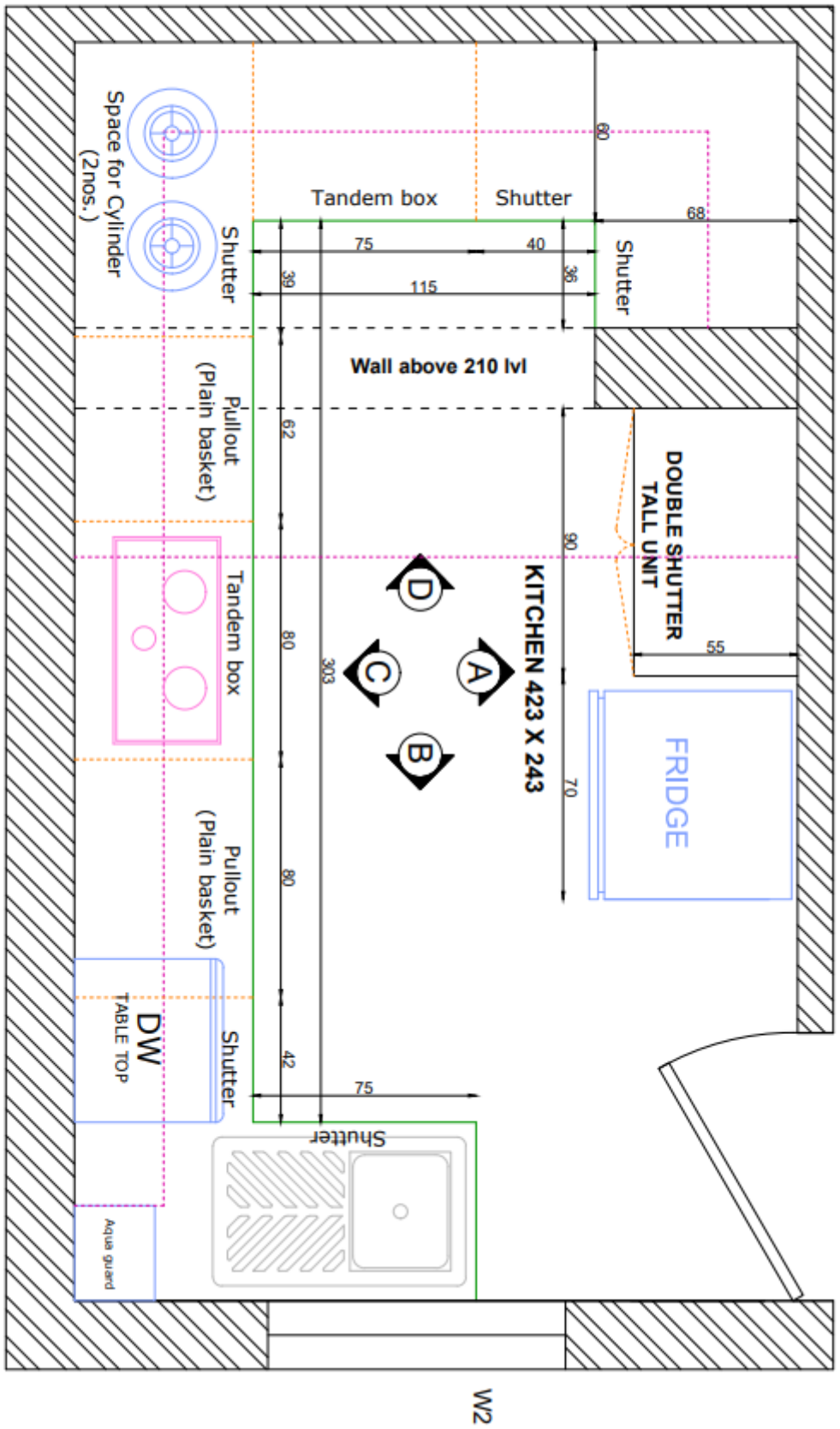

KITCHEN PLAN

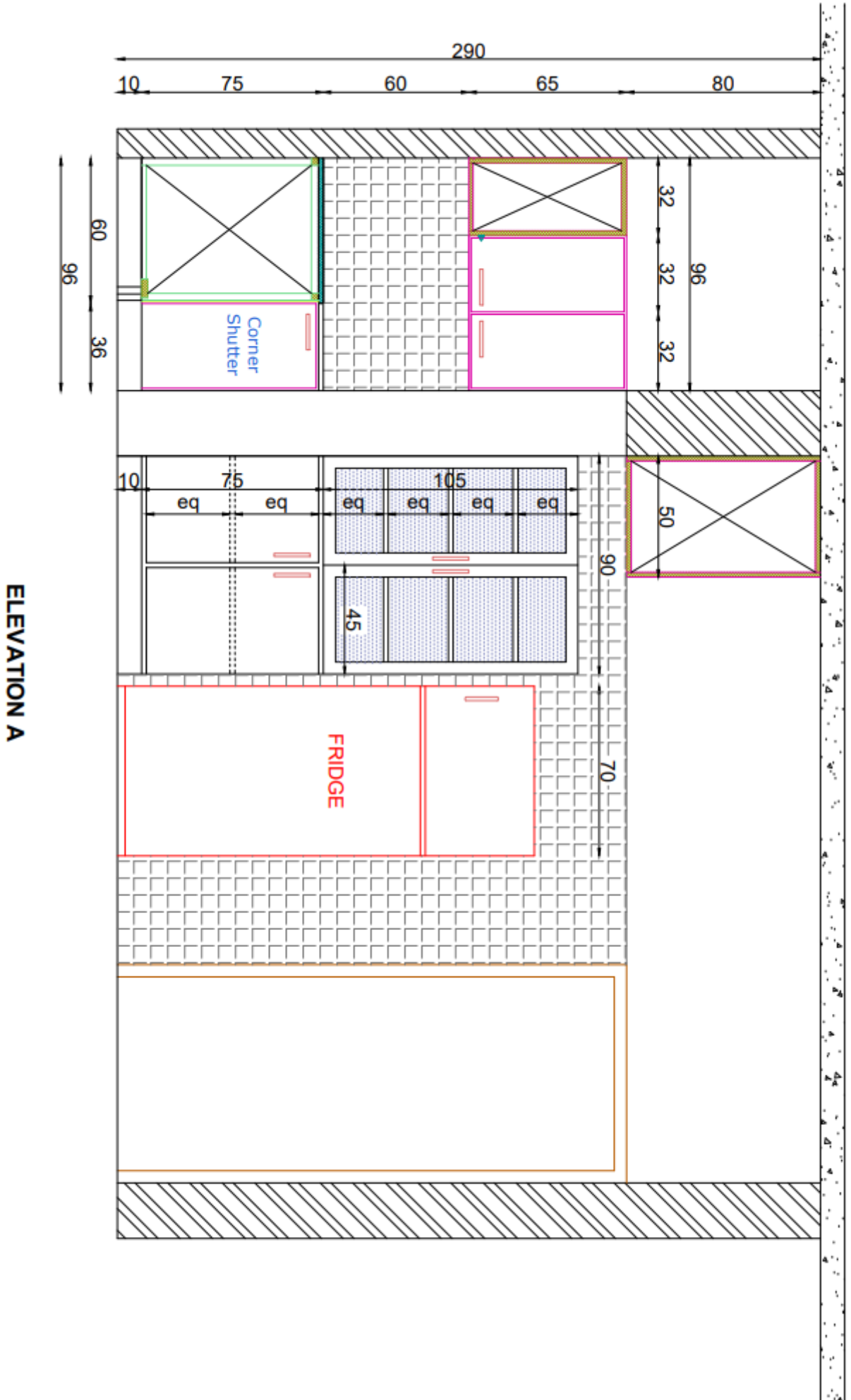

ELEVATION A

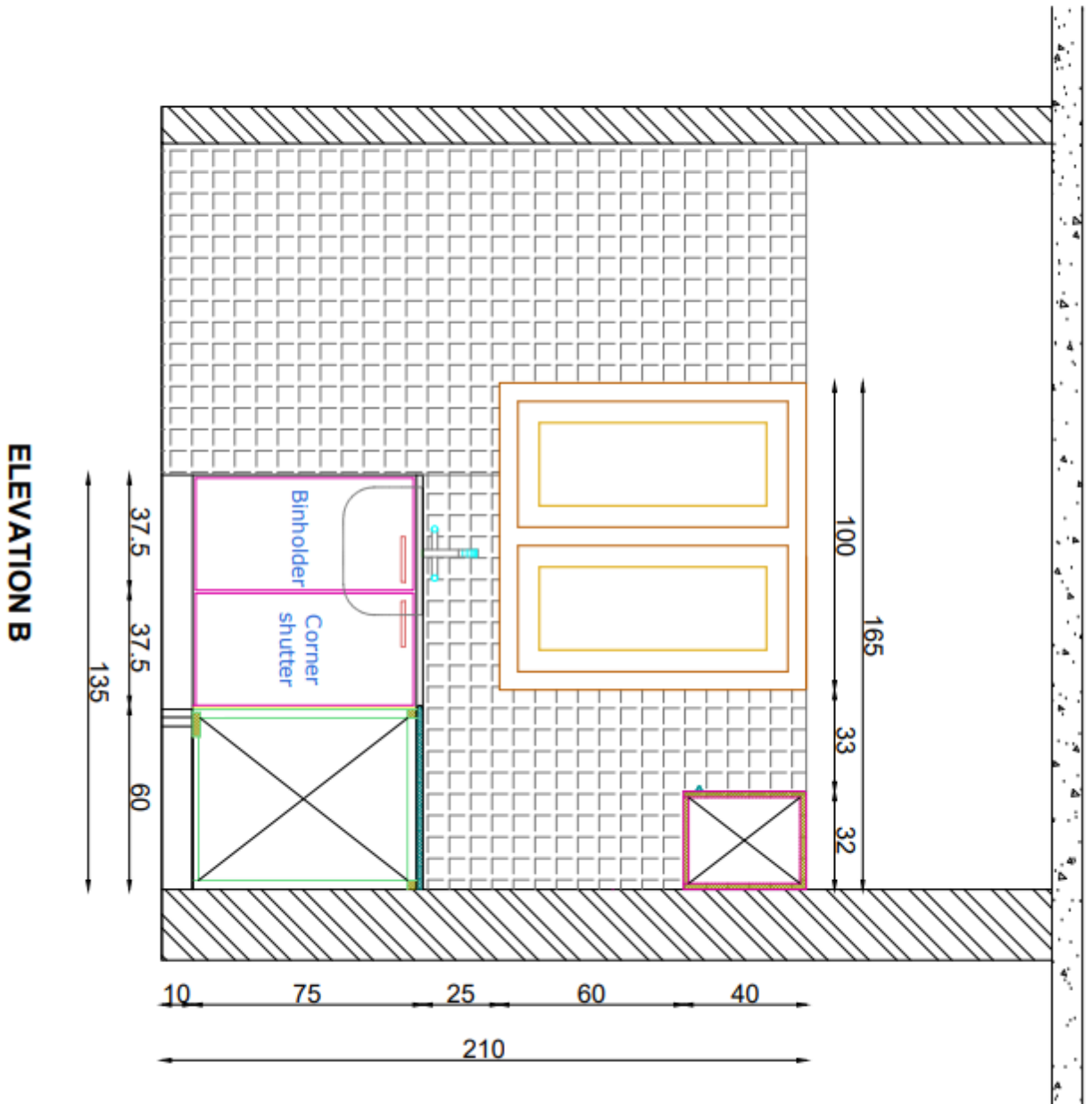

ELEVATION B

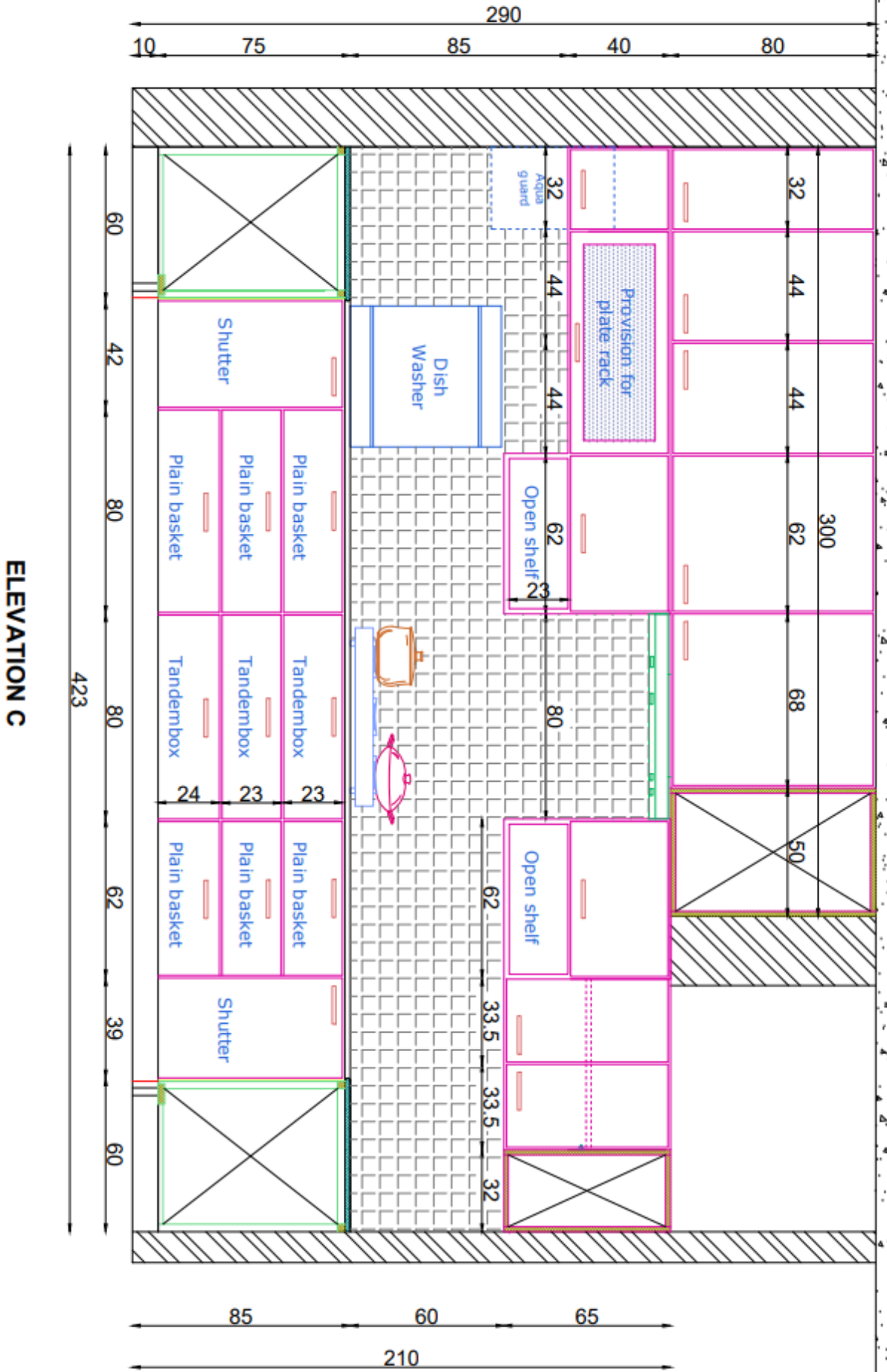

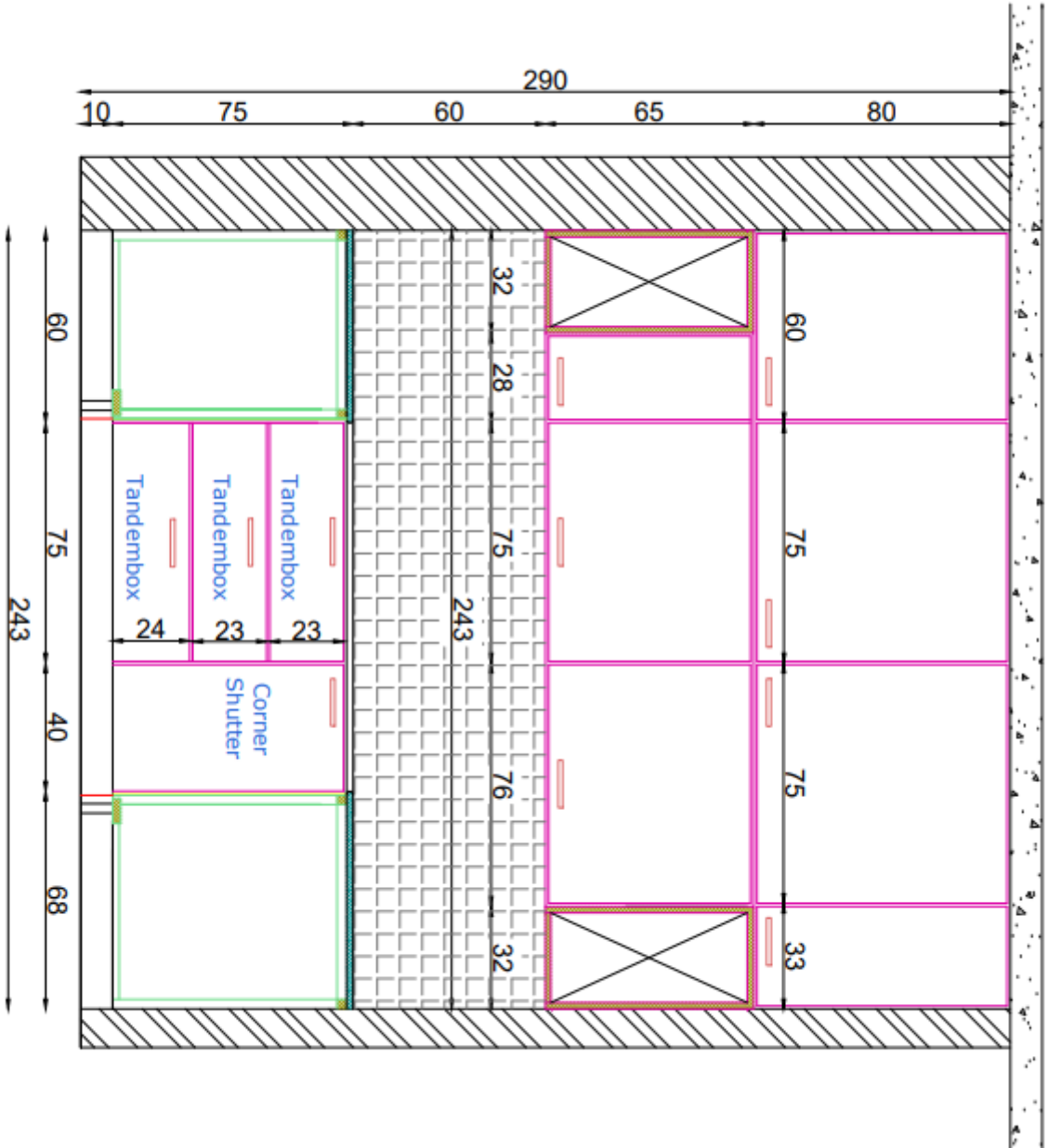

ELEVATION D